

Hoval Belaria® twin I/IR

Air/water heat pump

Belaria® twin I (20-30)

Belaria® twin IR (20-30)



Table of contents

■ Description	5
■ Part numbers	7
■ Technical data	18
■ Dimensions	26
■ Engineering General	33

Number of modules that can be additionally installed in the heat generator:

- 1 module expansion and 1 controller module
or
- 2 controller modules

The supplementary plug set must be ordered in order to use expanded controller functions.

Further information about the TopTronic® E
see "Controls"

EnergyManager PV smart

Feature to increase self-generated power consumption in use with HovalConnect.

If a HovalConnect gateway is used together with the heat pump, the EnergyManager PV smart feature is available. This allows the heat pump to be operated preferentially at times of higher solar radiation. The feature uses online weather data on the current solar radiation for this purpose and can be adjusted by means of an associated threshold value. The self-consumption of electricity from an existing photovoltaic plant is thus increased and the purchase of grid electricity is reduced. This results in a lasting and significant cost-saving potential without further investment costs for the customer.

Hoval Integrate

For seamless integration into intelligent home automation and energy management systems

With Hoval Integrate, Hoval heat pumps with TopTronic® E control can be integrated into home automation and energy management systems via open, standardised interfaces. Predefined templates, plugins and Smart Grid integrations simplify implementation and enable intelligent decisions.

Functions such as PV surplus utilisation, dynamic electricity tariffs, grid-friendly control, load management or simple visualisations for analysis purposes can be created and operated individually.

System integrators are free to choose their desired system and benefit from broad compatibility and future-proof sector coupling.

Thanks to integrated building automation, end customers benefit from operating cost savings and cross-system functions.

Practical guide videos provide additional support for integration and commissioning – step by step and with a practical orientation.

Notice

Only available in Austria, Germany and Switzerland

Air/water heat pump – 2-stage



Hoval Belaria® twin I

Belaria® twin I type	Heat output with A2W35 kW	
	stage 1	stage 2
(20)	10.4	20.8
(25)	12.5	25.0
(30)	15.2	30.4

Part No.

7019 020
7019 021
7019 022

**Air/water heat pump – 2-stage
(cooling function)**



Hoval Belaria® twin IR

Design as for Hoval Belaria® twin I,
but with cooling function

Belaria® twin IR type	Heat output with A2W35 kW		Cooling capacity with A35W18 kW	
	stage 1	stage 2	stage 1	stage 2
(20)	10.4	20.8	14.3	26.6
(25)	12.5	25.0	15.8	30.3
(30)	15.2	30.4	19.0	35.5

7019 023
7019 024
7019 025

EnergyManager PV smart

Feature to increase self-generated power consumption in use with HovalConnect.

Further information
see "Description"

Further accessories can be found under the following rubrics:

- Calorifiers/buffer storage tanks:
 - Calorifiers
 - Buffer storage tanks
 - Combination storage tanks
 - Electric heating elements
- Heating armature groups/heating distributors
- Various system components:
 - 2-way and 3-way valves
 - 3-way mixers
 - 2-way and 3-way ball valves
 - Motor drives and butterfly valves
 - Diaphragm pressure expansion tanks
 - Fittings
 - Plate heat exchangers
- Circulating pumps

Installation

The heat pump may be tilted by a maximum of 30° during transportation and installation.

Notice

Suitable charging pumps:

Hoval system pump set SPS-I with interface for pump control
Type 0-10 V or PWM1

Premium pump Stratos
with IF module Stratos Ext. Off (0-10 V)

See "Circulating pumps"

Notice

Only available in Austria, Germany and Switzerland

Hoval Integrate

For seamless integration into intelligent home automation and energy management systems

Further information
see "Description"

TopTronic® E module expansions
for TopTronic® E basic module heat generator

Part No.

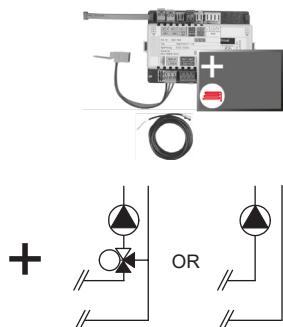

TopTronic® E module expansion heating circuit TTE-FE HK

Expansion to the inputs and outputs of the basic module heat generator or the heating circuit/domestic hot water module for implementing the following functions:

- 1 heating/cooling circuit without mixer or
- 1 heating/cooling circuit with mixer

Consisting of:

- Fitting accessories
- 1 contact sensor ALF/2P/4/T, L = 4.0 m
- Basic plug set FE module

Notice

The supplementary plug set may have to be ordered to implement functions differing from the standard!

6034 576

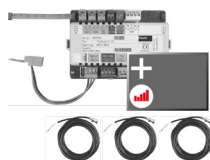

TopTronic® E module expansion heating circuit incl. energy balancing TTE-FE HK-EBZ

Expansion to the inputs and outputs of the basic module heat generator or the heating circuit/domestic hot water module for implementing the following functions:

- 1 heating/cooling circuit without mixer or
- 1 heating/cooling circuit with mixer incl. energy balancing in each case

Consisting of:

- Fitting accessories
- 3 contact sensors ALF/2P/4/T, L = 4.0 m
- Plug set FE module

Notice

The flow rate sensor set must be ordered as well.

6037 062

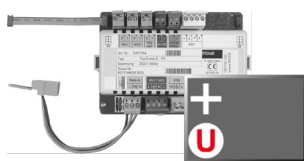

TopTronic® E module expansion Universal TTE-FE UNI

Expansion to the inputs and outputs of a controller module (basic module heat generator, heating circuit/domestic hot water module, solar module, buffer module) for implementing various functions

Consisting of:

- Fitting accessories
- Plug set FE module

Further information

see "Controls" – "Hoval TopTronic® E module expansions" chapter

Notice

Refer to the Hoval System Technology to find which functions and hydraulic arrangements can be implemented.

6034 575

Accessories for TopTronic® E



TopTronic® E controller modules

TTE-HK/WW	TopTronic® E heating circuit/ hot water module	6034 571
TTE-SOL	TopTronic® E solar module	6037 058
TTE-PS	TopTronic® E buffer module	6037 057
TTE-MWA	TopTronic® E measuring module	6034 574



Supplementary plug set

	for basic module heat generator TTE-WEZ	6034 499
	for controller modules and module expansion TTE-FE HK	6034 503



TopTronic® E room control modules

TTE-RBM	TopTronic® E room control modules easy white	6037 071
	comfort white	6037 069
	comfort black	6037 070



Enhanced language package TopTronic® E

	one SD card required per control module Consisting of the following languages: HU, CS, SL, RO, PL, TR, ES, HR, SR, JA, DA, NL	6039 253
--	---	----------



HovalConnect

	HovalConnect LAN	6049 496
	HovalConnect WLAN	6049 498
	HovalConnect Modbus	6049 501
	HovalConnect KNX	6049 593

TopTronic® E interface modules

	GLT module 0-10 V	6034 578
--	-------------------	----------



TopTronic® E sensors

AF/2P/K	Outdoor sensor H x W x D = 80 x 50 x 28 mm	2055 889
TF/2P/5/6T	Immersion sensor, L = 5.0 m	2055 888
ALF/2P/4/T	Contact sensor, L = 4.0 m	2056 775
TF/1.1P/2.5S/6T	Collector sensor, L = 2.5 m	2056 776



Bivalent switch

	for various release or switching functions	
	Bivalent switch 1-piece	2056 858
	Bivalent switch 2-piece	2061 826



System casing

	System casing 182 mm	6038 551
	System casing 254 mm	6038 552



TopTronic® E wall casing

WG-190	Wall casing small	6052 983
WG-360	Wall casing medium	6052 984
WG-360 BM	Wall casing medium with control module cut-out	6052 985
WG-510	Wall casing large	6052 986
WG-510 BM	Wall casing large with control module cut-out	6052 987

Further information
see "Controls"

Accessories



Hose set SPCH32-32-15-2
for Belaria® twin I/IR (20)
Consisting of:
- 2 reinforced hoses PN 10 DN 32 1¼" IT
insulated for heating side
flat-sealing with union nut
- Length: 1.5 m
- Seals

Part No.

6058 821



Hose set SPCH40-40-15-2
for Belaria® twin I/IR (25,30)
Consisting of:
- 2 reinforced hoses PN 10 DN 40 1½" IT
insulated for heating side
flat-sealing with union nut
- Length: 1.5 m
- Seals

6058 822



Flow rate sensor sets
Plastic casing
Balancing by means of pulse output and
PT1000 sensor element

Size	Connection inches	Flow rate l/min
DN 20	G 1¼"	5-85
DN 25	G 1½"	9-150

6038 509

6038 510



Brass casing
Balancing by means of analogue output 0-10 V

Size	Connection inches	Flow rate l/min
DN 32	G 1½"	14-240

6042 950

Hoval recommended use

Flow rate sensor set DN 32 made of brass.
Installation location outside the heat pump.

Recommended accessories:

speed-controlled high-efficiency pump
see "Circulating pumps"

Notice

Installation of a flow rate sensor set is recommended. With the help of flow rate sensors and further technical measures, the heating circuit freezing can be prevented. In order to protect the heat pump from frost in the event of a power failure or for example in bivalence mode, a system separation or other technical measures must be provided on site.

Part No.



Switching ball valve VBI60.32-13L; PN 40

Internal thread Rp 1½"
 Leakage rate: 0 ... 0.0001 % of kvs value
 Permitted media: cold water,
 cooling water, DHW, hot water,
 water with frost protection
 Recommendation:
 water treatment according to VDI 2035
 DN 32
 kvs value: 13 m³/h
 Medium temperature: -10 ... 120 °C
 Ball valve body: brass
 Ball: brass chrome-plated
 Tappet: brass
 Gland: EPDM O-rings

6052 445



Switching ball valve VBI60.40-25L; PN 40

Internal thread Rp 1½"
 Leakage rate: 0 ... 0.0001 % of kvs value
 Permitted media: cold water,
 cooling water, DHW, hot water,
 water with frost protection
 Recommendation:
 water treatment according to VDI 2035
 DN 40
 kvs value: 25 m³/h
 Medium temperature: -10 ... 120 °C
 Ball valve body: brass
 Ball: brass chrome-plated
 Tappet: brass
 Gland: EPDM O-rings

6052 446



Motor drive GLB341.9E

For straight-way ball valves VAG60.. and
 switching ball valves VBI60.. DN 15-50
 Operating voltage: 230 V, 50/60 Hz
 Control signal 2-point/3-point
 Single-wire/2 wire control
 Operating time: 150 s
 Nominal torque: 10 Nm
 Permitted ambient temperature:
 -32 ... 55 °C

2070 331



Safety set SGK15-PN3 IT 1" insulated

Safety group made of composite material
 (glass fiber reinforced polyamide)
 complete with safety valve (3 bar),
 quick air vent and pressure gauge
 Connection IT 1" (ISO228-1)
 with insulating caps
 Medium temperature range: 5 ... 90 °C
 Setting (pressure): 3 bar
 Area of application up to 50 kW

6063 905



Vibration decoupler

for reducing structure-borne noise from heat pumps in the indoor area, cannot be shortened
Consisting of:

- 1 vibration decoupler insulated for heating and brine side flat-sealing with union nut
- 2 flat seals

Nominal pressure: PN 10

Dimension	Connection inches	Nominal length mm
DN 32	1¼"	300
DN 32	1¼"	500
DN 32	1¼"	1000
DN 40	1½"	500
DN 40	1½"	1000

Part No.

2082 224
2082 225
2080 796
2082 226
2080 798

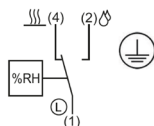

Dewpoint monitor (TPW)

for monitoring the formation of condensation in a compartment, with gold contacts, can be installed as required for pipes up to Ø 50 mm
The installation location must be selected in such a way that a representative humidity measurement is guaranteed i.e. the room air must flow unhindered through the slots in the housing to the measuring element inside the casing.

The TPW does not require supply voltage or auxiliary energy and should be mounted in an air flow with an air velocity of at least 0.2 m/s.

Control range: 50 ... 90 % RH
Max. switch power: 100 mA/250 V AC
Operating temperature: 0 ... 60 °C
Dimensions: 85 x 55 x 33 mm
Weight: approx. 92 g
Type of protection: IP20

2070 911

Notice

The dewpoint monitor is the only safety equipment in cooling systems and is always mandatory, to prevent damage caused by condensing water in surface cooling systems (floor, wall, ceiling cooling)!
This applies to both active and passive cooling systems.

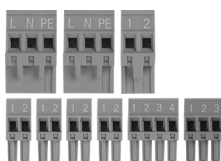

Expansion connector set

for the automatic heat pump device ECR461

Use for additional function:

- Flow monitor
- Crankcase bottom heating
- Condensation drain heating
- Heat quantity metering

Plugs:

- 1 230 V digital input
- 2 230 V outputs
- 4 low-voltage inputs
- 1 ratio. Input
- 1 4-pin low-voltage input

6032 509



Universal plug set

for automatic heat pump device ECR461

Plugs:

- 3 digital 230 V inputs
- 4 230 V outputs
- 6 low-voltage inputs
- 2 low-voltage outputs
- 1 ratio. input
- 1 electronic expansion valve
- 1 4-pin low-voltage input

6032 510

Accessories of the air ducting

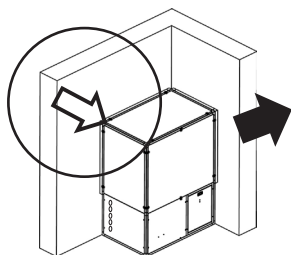

Indoor installation “standard”

Installation directly on the wall

Intake



Wall connection element WAE1 for intake
for Belaria® twin I/IR (20)
for sealing the intake side directly
on the wall
black synthetic rubber, 50 mm

2033 866



Wall connection element WAE1 for intake
for Belaria® twin I/IR (25,30)
for sealing the intake side directly
on the wall
black synthetic rubber, 50 mm

2033 868

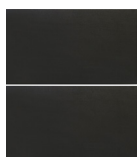

Wall insulation 1250 x 600 x 20
for Belaria® comfort ICM (8,13),
for Belaria® twin I/IR (20-30)
for intake and exhaust

2076 728



Weatherproof grille WG1
for Belaria® twin I/IR (20) – intake
Outer dimensions (H x W x D):
1030 x 1230 x 68 mm
suitable for wall insulation
1250 x 600 x 20
For intake, made of aluminium
with grilles

6062 080



Weatherproof grille WG1
for Belaria® twin I/IR (25,30) – intake
Outer dimensions (H x W x D):
1230 x 1330 x 68 mm
suitable for wall insulation
1250 x 600 x 20
For intake, made of aluminium
with grilles

6062 081



Weatherproof grille WG1 sound-insulated
 for Belaria® twin I/IR (20) – intake
 Outer dimensions (H x W x D):
 1030 x 1230 x 195 mm
 suitable for wall insulation
 1250 x 600 x 20
 For intake, made of aluminium
 with grilles
 Reduction of sound power level 5 dB(A)

Part No.
 2076 723



Weatherproof grille WG1 sound-insulated
 for Belaria® twin I/IR (25,30) – intake
 Outer dimensions (H x W x D):
 1230 x 1330 x 195 mm
 suitable for wall insulation
 1250 x 600 x 20
 For intake, made of aluminium
 with grilles
 Reduction of sound power level 5 dB(A)

2076 726

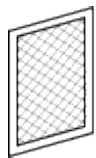

Mesh grille MG1 for intake
 for Belaria® twin I/IR (20)
 suitable for wall insulation
 1250 x 600 x 20
 Replaces weatherproof grille WG1
 for air duct

2033 816

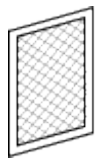

Mesh grille MG1 for intake
 for Belaria® twin I/IR (25,30)
 suitable for wall insulation
 1250 x 600 x 20
 Replaces weatherproof grille WG1
 for air duct

2033 818

Accessories of the air ducting

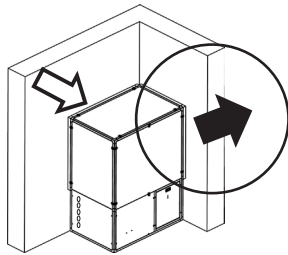

Indoor installation “standard”

Installation directly on the wall

Exhaust



Wall connection element WAE2 for exhaust
for Belaria® twin I/IR (20)
black synthetic rubber, 50 mm
for sealing the intake side directly
on the wall

2033 871



Wall connection element WAE2 for exhaust
for Belaria® twin I/IR (25,30)
black synthetic rubber, 50 mm
for sealing the intake side directly
on the wall

2033 872

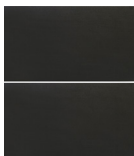

Wall insulation 1250 x 600 x 20
for Belaria® comfort ICM (8,13),
for Belaria® twin I/IR (20-30)
for intake and exhaust

2076 728



Weatherproof grille WG2
for Belaria® twin I/IR (20) – exhaust
Outer dimensions (H x W x D):
1030 x 910 x 68 mm
suitable for wall insulation
1250 x 600 x 20
For exhaust, made of aluminium
with grilles

6062 082



Weatherproof grille WG2
for Belaria® twin I/IR (25,30) – exhaust
Outer dimensions (H x W x D):
1230 x 1010 x 68 mm
suitable for wall insulation
1250 x 600 x 20
For exhaust, made of aluminium
with grilles

6062 083



Weatherproof grille WG2 sound-insulated
for Belaria® twin I/IR (20) – exhaust
Outer dimensions (H x W x D):
1030 x 910 x 195 mm
suitable for wall insulation
1250 x 600 x 20
For exhaust, made of aluminium
with grilles
Reduction of sound power level 5 dB(A)

2076 725



Weatherproof grille WG2 sound-insulated
for Belaria® twin I/IR (25,30)
suitable for wall insulation
1250 x 600 x 20
For exhaust, made of aluminium
with grilles
Reduction of sound power level 5 dB(A)

2076 727

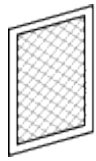

Mesh grille MG2 for exhaust
for Belaria® twin I/IR (20)
suitable for wall insulation 1250 x 600 x 20
Replaces weatherproof grille WG2
for air duct

2033 821

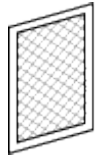

Mesh grille MG2 for exhaust
for Belaria® twin I/IR (25,30)
suitable for wall insulation 1250 x 600 x 20
Replaces weatherproof grille WG2
for air duct

2033 822

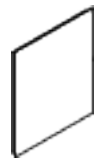

Side panel
for Belaria® twin I/IR (20)
Side wall for covering the exhaust
opening on the side. Required if
the exhaust is upwards or if on-site
air ducts are used.

6020 596

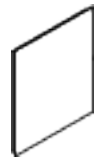

Side panel
for Belaria® twin I/IR (25,30)
Side wall for covering the exhaust
opening on the side. Required if
the exhaust is upwards or if on-site
air ducts are used.

6020 595

**Installation with cold ambient
temperature**

Necessary for heating room temperatures < 10 °C



Crankcase heater
for Belaria® twin I/IR (20-30),
Thermalia® comfort (8-17),
Thermalia® comfort H (7,10)
(1 piece required per heat pump)

6019 718

Thermalia® twin (20-42),
Thermalia® twin H (13-22),
Thermalia® dual, dual H, dual R
(2 pieces required per heat pump)

Services



Services and associated scope of services
see separate catalogue "Hoval Services"

Commissioning by Hoval customer service is a prerequisite for warranty/guarantee activation.

Part No.

Belaria® twin I

Type		(20)		(25)		(30)	
		1st stage	2nd stage	1st stage	2nd stage	1st stage	2nd stage
• Energy efficiency class of the compound system with control (A+++ → D)	35 °C/55 °C	A++/A+		A++/A+		A++/A+	
• Room heating energy efficiency «moderate climate» 35 °C η _S ^{1), 2)}	%	153		152		150	
• Room heating energy efficiency «moderate climate» 55 °C η _S ^{1), 2)}	%	111		111		112	
• Seasonal coefficient of performance moderate climate 35 °C/55 °C	SCOP	3.9/2.9		3.9/2.9		3.8/2.9	
Max. performance data heating in acc. with EN							
• Heat output A2W35	kW ³⁾	10.4	20.8	12.5	25.0	15.2	30.4
• Coefficient of performance A2W35	COP	3.9	3.5	3.9	3.5	3.8	3.4
• Heat output A-7W35	kW ³⁾	8.8	17.6	9.4	20.8	12.2	24.4
• Coefficient of performance A-7W35	COP	3.4	3.1	2.8	3.0	3.7	3.1
Sound data							
• Sound power level EN 12102 (inside)	dB(A)	58		60		61	
• Sound power level EN 12102 (outlet) ⁴⁾	dB(A)	64		66		67	
• Sound pressure level 5 m	dB(A)	45		47		48	
• Sound pressure level 10 m	dB(A)	39		41		42	
Hydraulic data							
• Max. flow temperature	°C	55		55		55	
• Max. operating pressure on the heating side	bar	6		6		6	
• Flow/return connection heating	R (ext. thread)	1¼"		1½"		1½"	
• Pressure drop heat pump	kPa	15		17		15	
• Nominal heating water quantity	m ³ /h	4.5		4.9		5.1	
• Nominal air volume	m ³ /h	3000-6000		3800-7500		4500-9000	
• Externally available pressure	Pa	200		200		200	
• Max. speed in air ducts	m/s	3		3		3	
Cooling technical data							
• Compressor		stage		stage		stage	
• Refrigerant		R407C		R407C		R407C	
• Refrigerant filling quantity	kg	11.3		12.5		13.0	
• Type of compressor oil		Emkarate RL32-3MAF		Emkarate RL32-3MAF		Emkarate RL32-3MAF	
• Compressor oil filling quantity	l	2 x 1.89		2 x 1.89		2 x 1.89	
Electrical data							
• Electrical connection compressor	V/Hz	3~400/50		3~400/50		3~400/50	
• Electrical connection fan	V/Hz	3~400/50		3~400/50		3~400/50	
• Electrical connection control	V/Hz	1~230/50		1~230/50		1~230/50	
• Max. heat pump operating current	A	14.6		17.9		21.9	
• Compressor power consumption A2W35	kW	2.67	5.9	3.2	7.1	4.0	8.9
• Compressor power consumption A20W55	kW	4.1	9.1	5.2	11.5	5.8	12.8
• Max. starting current heat pump (with jump start)	A	24.2		29.7		35.1	
• External protection main current	A	16		20		25	
• External protection main current	Type	C,D,K		C,D,K		C,D,K	
• External protection control current	A	13		13		13	
• External protection control current	Type	B,C,D,K,Z		B,C,D,K,Z		B,C,D,K,Z	
Dimensions/weight							
• Dimensions (H x W x D)	mm	1735 x 1200 x 880			1935 x 1300 x 980		
• Weight	kg	400		455		485	
• Minimum sizes of installation room (without ventilator)	m ³	27.6		30.5		31.7	

¹⁾ 2 % can be added for class II heat pump incl. control.

²⁾ 4 % can be added for class IV heat pump incl. control and room thermostat.

³⁾ kW = incl. defrosting loss

⁴⁾ The sound power levels apply in whisper mode. Values increase by + 4 dB(A) in normal operation.

⁵⁾ If the installation room is smaller than the required minimum size, it must be designed as a machine room in accordance with EN 378.

Using a fault-current circuit breaker RCCB type B, I_{Δn} ≥ 300 mA must be clarified based on the regulations of the country in question.

Belaria® twin IR

Type		(20)		(25)		(30)	
		1st stage	2nd stage	1st stage	2nd stage	1st stage	2nd stage
• Energy efficiency class of the compound system with control (A+++ → D)	35 °C/55 °C	A++/A+		A++/A+		A++/A+	
• Room heating energy efficiency «moderate climate» 35 °C ηS ^{1), 2)}	%	155		153		151	
• Room heating energy efficiency «moderate climate» 55 °C ηS ^{1), 2)}	%	112		112		113	
• Seasonal coefficient of performance moderate climate 35 °C/55 °C	SCOP	3.9/2.9		3.9/2.9		3.8/2.9	
Max. performance data heating and cooling in acc. with EN 14511							
• Heat output A2W35	kW ³⁾	10.4	20.8	12.5	25.0	15.2	30.4
• Coefficient of performance A2W35	COP	3.9	3.5	3.9	3.5	3.8	3.4
• Heat output A-7W35	kW ³⁾	8.8	17.6	9.4	20.8	12.2	24.4
• Coefficient of performance A-7W35	COP	3.4	3.1	2.8	3.0	3.7	3.1
• Cooling capacity A35W18	kW	14.3	26.6	15.8	30.3	19.0	35.5
• Energy efficiency ratio A35W18	EER	3.6	3.1	3.4	3.0	3.3	2.9
• Cooling capacity A35W7	kW	10.2	19.0	10.8	22.0	13.2	24.7
• Energy efficiency ratio A35W7	EER	2.8	2.5	2.6	2.4	2.6	2.3
Sound data							
• Sound power level EN 12102 (inside)	dB(A)	58		60		61	
• Sound power level EN 12102 (outlet) ⁴⁾	dB(A)	63		65		66	
• Sound pressure level 5 m	dB(A)	44		46		47	
• Sound pressure level 10 m	dB(A)	38		40		41	
Hydraulic data							
• Max. flow temperature	°C	55		55		55	
• Max. operating pressure on the heating side	bar	6		6		6	
• Flow/return connection heating	R (ext. thread)	1¼"		1½"		1½"	
• Pressure drop heat pump	kPa	15		17		15	
• Nominal heating water quantity	m ³ /h	4.5		4.9		5.1	
• Nominal air volume	m ³ /h	3000-6000		3800-7500		4500-9000	
• Externally available pressure	Pa	200		200		200	
• Max. speed in air ducts	m/s	3		3		3	
Cooling technical data							
• Compressor		stage		stage		stage	
• Refrigerant		R407C		R407C		R407C	
• Refrigerant filling quantity	kg	13		18.3		19.8	
• Type of compressor oil		Emkarate		Emkarate		Emkarate	
• Compressor oil filling quantity	l	RL32 – 3MAF 2 x 1.89		RL32 – 3MAF 2 x 1.89		RL32 – 3MAF 2 x 1.89	
Electrical data							
• Electrical connection compressor	V/Hz	3~400/50		3~400/50		3~400/50	
• Electrical connection fan	V/Hz	3~400/50		3~400/50		3~400/50	
• Electrical connection control	V/Hz	1~230/50		1~230/50		1~230/50	
• Max. heat pump operating current	A	14.6		17.9		21.9	
• Compressor power consumption A2W35	kW	2.67	5.94	3.21	7.14	4	8.94
• Compressor power consumption A20W55	kW	4.1	9.1	5.19	11.54	5.76	12.8
• Max. starting current heat pump (with jump start)	A	24.2		29.7		35.1	
• External protection main current	A	16		20		25	
• External protection main current	Type	C,D,K		C,D,K		C,D,K	
• External protection control current	A	13		13		13	
• External protection control current	Type	B,C,D,K,Z		B,C,D,K,Z		B,C,D,K,Z	
Dimensions/weight							
• Dimensions (H x W x D)	mm	1735 x 1200 x 880			1935 x 1300 x 980		
• Weight	kg	400		455		485	
• Minimum sizes of installation room (without ventilator m ³)		31.7		44.6		48.3	

¹⁾ 2 % can be added for class II heat pump incl. control.

²⁾ 4 % can be added for class IV heat pump incl. control and room thermostat.

³⁾ kW = incl. defrosting loss

⁴⁾ The sound power levels apply in whisper mode. Values increase by + 4 dB(A) in normal operation.

⁵⁾ If the installation room is smaller than the required minimum size, it must be designed as a machine room in accordance with EN 378.

Using a fault-current circuit breaker RCCB type B, IΔn ≥ 300 mA must be clarified based on the regulations of the country in question.

Diagrams of areas of application

Belaria® twin I (20-30), Belaria® twin IR (20-30)
Heating

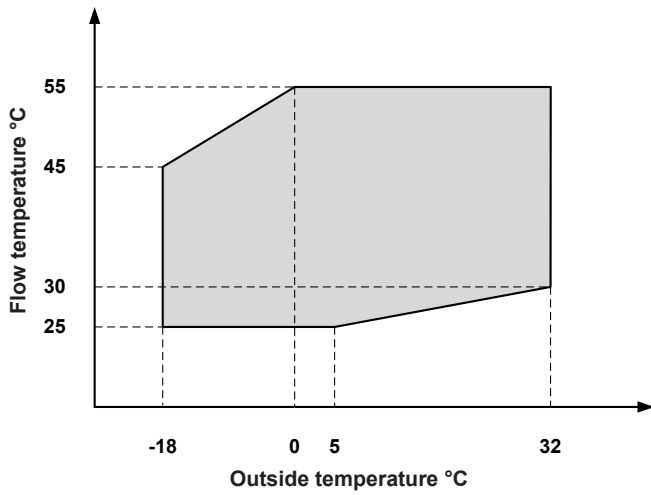

Area of application of the heat pump for heating

Belaria® twin I (20-30), Belaria® twin IR (20-30)
Hot water

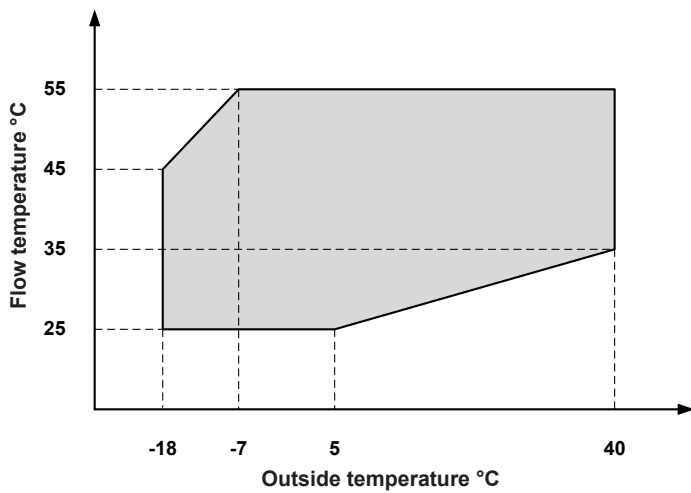

Area of application of the heat pump for domestic hot water

Belaria® twin IR (20-30)
Cooling

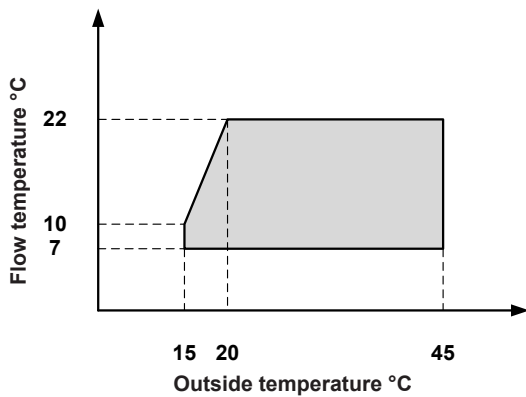

Area of application of the heat pump for cooling

Belaria® twin I, twin IR (20-30)

Sound pressure level – sound power level

The **sound pressure level** is dependent on the **place of measurement** in a sound field and describes the sound intensity at this place. The sound power level thus is a feature of the sound source and therefore is distance-unrelated; it describes the totality of sound power of the relevant source radiated into all directions.

The effective sound pressure in the installation room depends on various factors such as room size, absorption capacity, reflection, free sound propagation etc.

For this reason, it is important to ensure that where possible, the boiler room is outside noise-sensitive areas of the building and equipped with a sound-absorbing door.

“Standard” installation with wall insulation MI

Belaria® twin I, twin IR		(20)		(25)		(30)	
Stage		1	2	1	2	1	2
Sound power level in the installation room	dB(A)	55	58	57	60	58	61

Exhaust and intake directly through the wall

The sound pressure levels indicated below apply if the air intake and exhaust are positioned across a corner from each other on a straight wall without roofing.

“Standard” installation with wall insulation MI

Belaria® twin I		(20)		(25)		(30)	
		1	2	1	2	1	2
Sound power level ¹⁾	dB(A)	60	64	62	66	63	67
Sound pressure level 5 m ¹⁾	dB(A)	41	45	43	47	44	48
Sound pressure level 10 m ¹⁾	dB(A)	35	39	37	41	38	42

Belaria® twin IR		(20)		(25)		(30)	
		1	2	1	2	1	2
Sound power level ¹⁾	dB(A)	60	63	62	65	63	66
Sound pressure level 5 m ¹⁾	dB(A)	41	45	43	47	44	48
Sound pressure level 10 m ¹⁾	dB(A)	35	39	37	41	38	42

¹⁾ Information on sound levels applies to whisper mode.
Values increase by + 4 dB(A) in normal operation

Reduced sound levels (outside) as a result of the installation situation

The following reductions in the sound levels can be assumed as a result of the installation of the following components in the air duct:

- Light well from a depth of 1.5 m: - 4 dB(A)
- Air duct insulated on the inside with 90° elbow, L < 2 m: - 6 dB(A)
- Air duct insulated on the inside with 90° elbow, L > 2 m: - 8 dB(A)

Performance data – heating

Maximum heat output allowing for defrosting losses

Belaria® twin I (20-30), twin IR (20-30)

Data according to EN 14511

Heat output – t_{VL} 35 °C

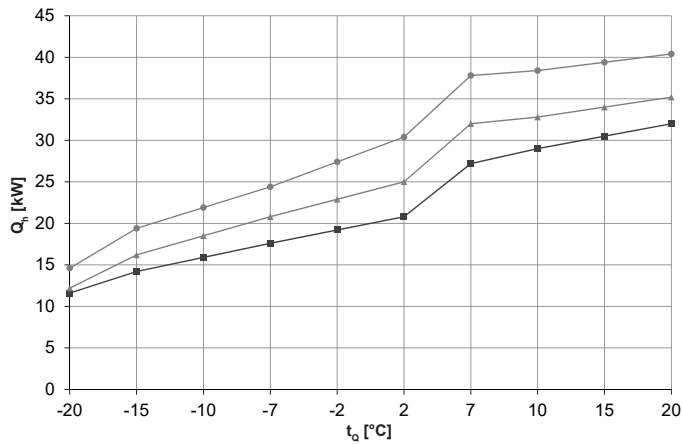

Coefficient of performance – t_{VL} 35 °C

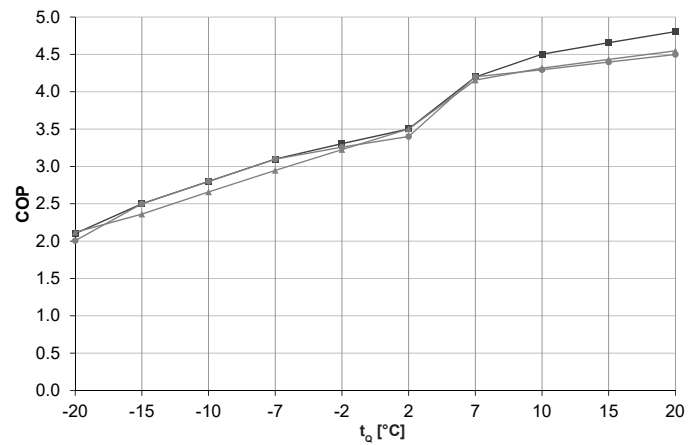

Heat output – t_{VL} 45 °C

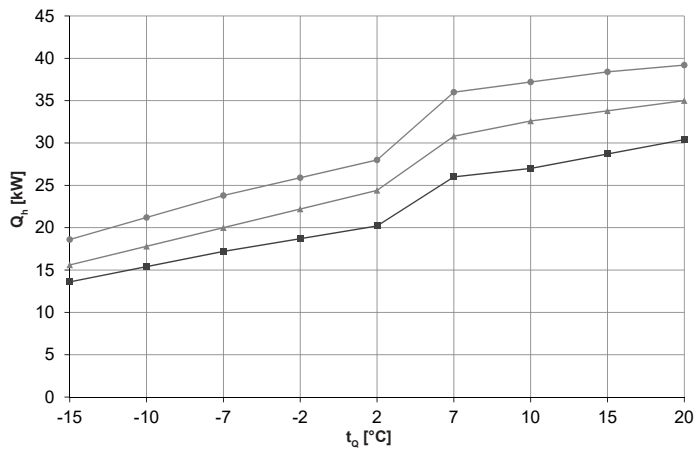

Coefficient of performance – t_{VL} 45 °C

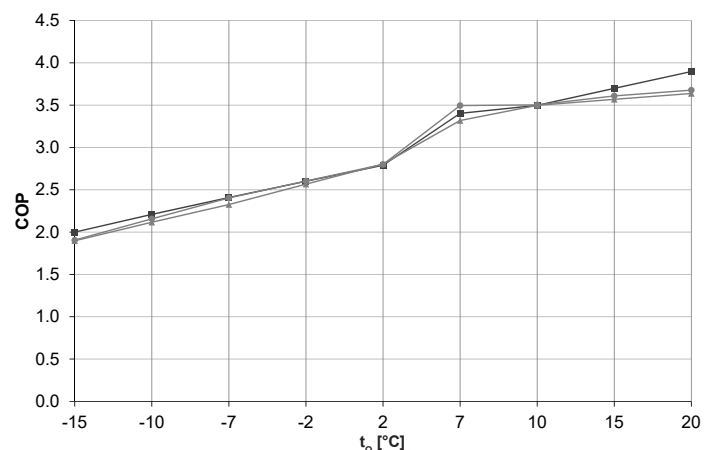

Heat output – t_{VL} 55 °C

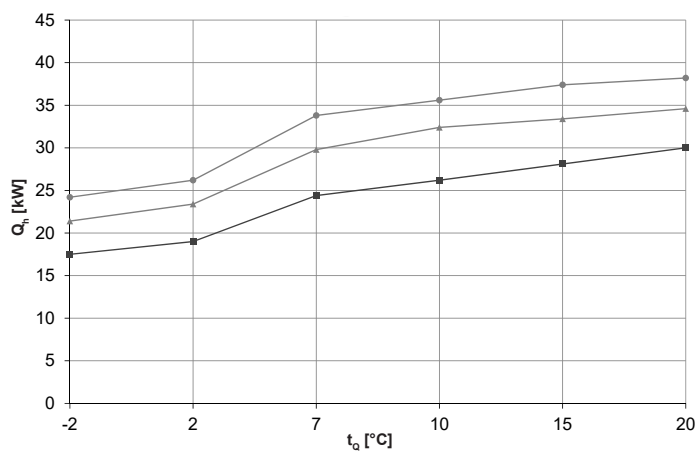

Coefficient of performance – t_{VL} 55 °C

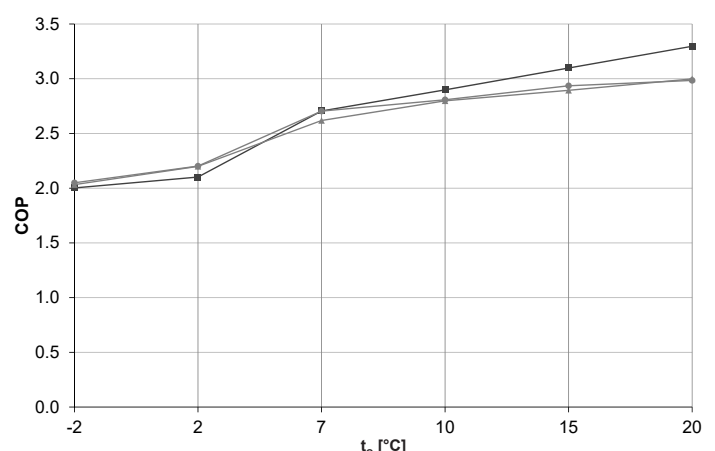

t_{VL} = heating flow temperature (°C)

t_o = source temperature (°C)

Q_h = heat output at full load (kW), measured in accordance with standard EN 14511

COP = Coefficient of Performance for the overall unit in accordance with standard EN 14511

■ Belaria® twin I/IR (20)

▲ Belaria® twin I/IR (25)

● Belaria® twin I/IR (30)

Performance data – heating

Belaria® twin I (20-30), twin IR (20-30)

Data according to EN 14511

t_{VL} °C	t_Q °C	(20) Stage 2			(25) Stage 2			(30) Stage 2		
		Q_h kW	P kW	COP	Q_h kW	P kW	COP	Q_h kW	P kW	COP
35	-20	11.6	5.5	2.1	12.2	5.8	2.1	14.6	7.3	2.0
	-15	14.2	5.7	2.5	16.2	6.9	2.4	19.4	7.8	2.5
	-10	15.9	5.7	2.8	18.5	7.0	2.7	21.9	7.8	2.8
	-7	17.6	5.7	3.1	20.8	7.1	3.0	24.4	7.9	3.1
	-2	19.2	5.8	3.3	22.9	7.1	3.2	27.4	8.4	3.3
	2	20.8	5.9	3.5	25.0	7.1	3.5	30.4	8.9	3.4
	7	27.2	6.5	4.2	32.0	7.7	4.2	37.8	9.0	4.2
	10	29.0	6.4	4.5	32.8	7.6	4.3	38.4	8.9	4.3
	15	30.5	6.6	4.7	34.0	7.7	4.4	39.4	9.0	4.4
	20	32.0	6.7	4.8	35.2	7.7	4.6	40.4	9.0	4.5
45	-15	13.6	6.8	2.0	15.6	8.2	1.9	18.6	9.8	1.9
	-10	15.4	7.0	2.2	17.8	8.4	2.1	21.2	9.8	2.2
	-7	17.2	7.1	2.4	20.0	8.6	2.3	23.8	9.9	2.4
	-2	18.7	7.2	2.6	22.2	8.7	2.6	25.9	10.0	2.6
	2	20.2	7.2	2.8	24.4	8.7	2.8	28.0	10.0	2.8
	7	26.0	7.6	3.4	30.8	9.3	3.3	36.0	10.3	3.5
	10	27.0	7.7	3.5	32.6	9.3	3.5	37.2	10.6	3.5
	15	28.7	7.8	3.7	33.8	9.5	3.6	38.4	10.6	3.6
20	30.4	7.8	3.9	35.0	9.6	3.6	39.2	10.7	3.7	
55	-2	17.5	8.7	2.0	21.4	10.5	2.0	24.2	11.8	2.1
	2	19.0	9.0	2.1	23.4	10.6	2.2	26.2	11.9	2.2
	7	24.4	9.0	2.7	29.8	11.4	2.6	33.8	12.5	2.7
	10	26.2	9.0	2.9	32.4	11.6	2.8	35.6	12.7	2.8
	15	28.1	9.1	3.1	33.4	11.5	2.9	37.4	12.7	2.9
20	30.0	9.1	3.3	34.6	11.5	3.0	38.2	12.8	3.0	

- t_{VL} = heating flow temperature (°C)
- t_Q = source temperature (°C)
- Q_h = heat output at full load (kW), measured in accordance with standard EN 14511
- P = power consumption of the overall unit (kW)
- COP = Coefficient of Performance for the overall unit in accordance with standard EN 14511

Observe daily power interruptions!
see "Engineering heat pumps general"

Performance data – cooling

Maximum cooling capacity

Belaria® twin IR (20-30)

Data according to EN 14511

Cooling capacity – t_{VL} 7 °C

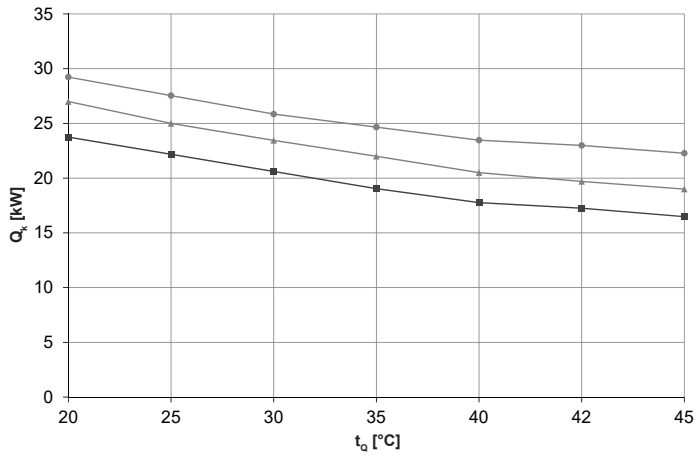

Energy efficiency ratio – t_{VL} 7 °C

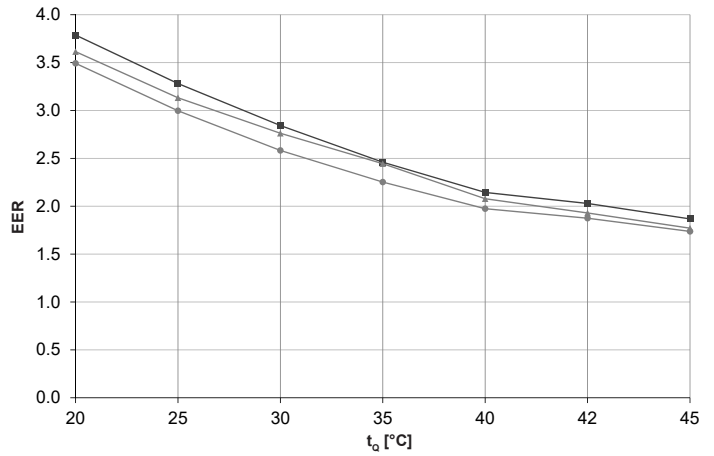

Cooling capacity – t_{VL} 13 °C

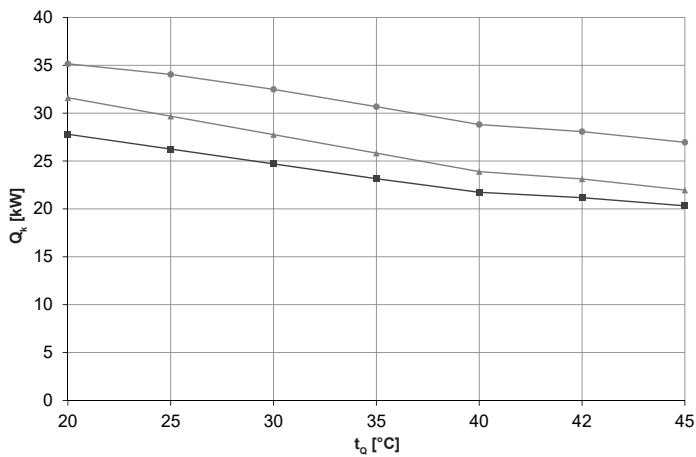

Energy efficiency ratio – t_{VL} 13 °C

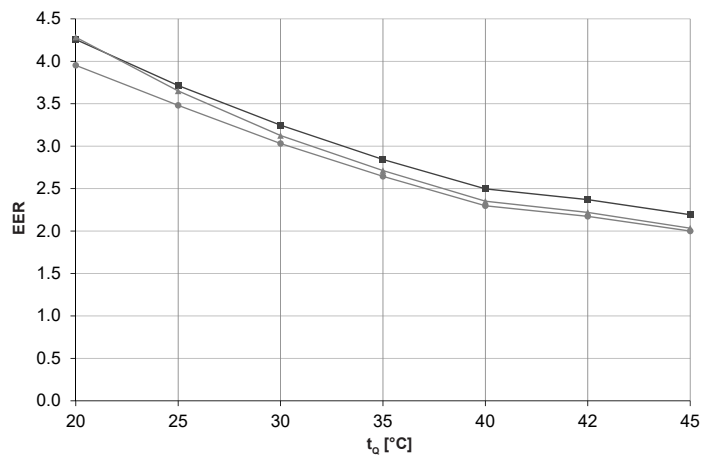

Cooling capacity – t_{VL} 18 °C

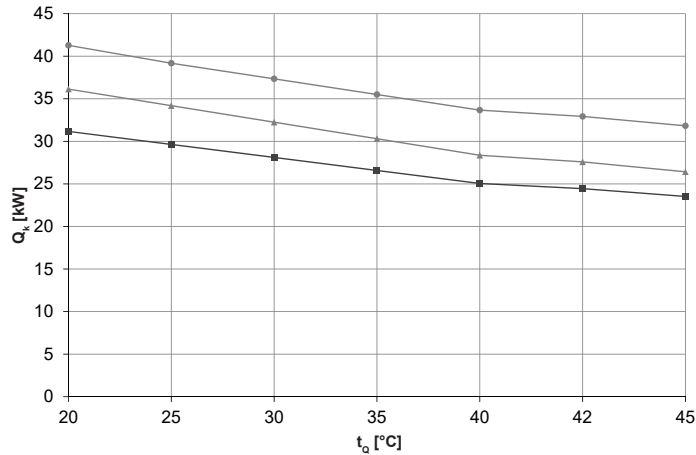

Energy efficiency ratio – t_{VL} 18 °C

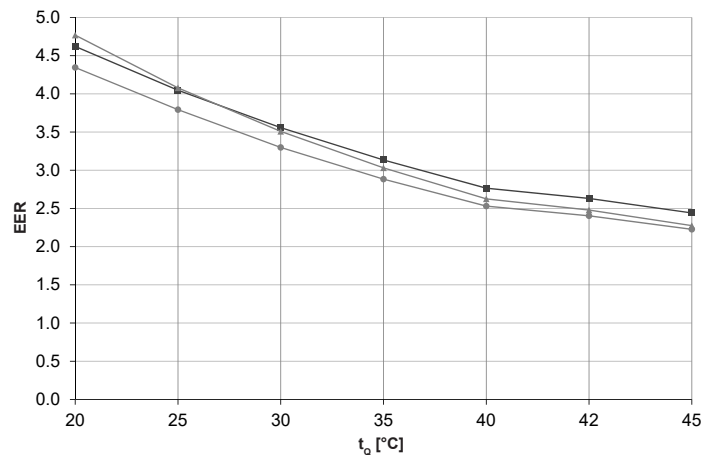

t_{VL} = cooling water flow temperature (°C)
 t_o = source temperature (°C)
 Q_k = cooling capacity at full load (kW), measured in accordance with standard EN 14511
 EER = Energy Efficiency Ratio for the overall unit in accordance with standard EN 14511

■ Belaria® twin IR (20)
 ▲ Belaria® twin IR (25)
 ● Belaria® twin IR (30)

Performance data – cooling

Belaria® twin IR (20-30)

Data according to EN 14511

t_{VL} °C	t_Q °C	(20) Stage 2			(25) Stage 2			(30) Stage 2		
		Q_k kW	P kW	EER	Q_k kW	P kW	EER	Q_k kW	P kW	EER
7	20	23.8	6.3	3.8	27.0	7.5	3.6	29.2	8.4	3.5
	25	22.2	6.8	3.3	25.0	8.0	3.1	27.5	9.2	3.0
	30	20.6	7.3	2.8	23.5	8.5	2.8	25.9	10.0	2.6
	35	19.0	7.7	2.5	22.0	9.0	2.4	24.7	10.9	2.3
	40	17.8	8.3	2.1	20.5	9.9	2.1	23.5	11.9	2.0
	42	17.3	8.5	2.0	19.7	10.2	1.9	23.0	12.3	1.9
	45	16.5	8.8	1.9	19.0	10.7	1.8	22.3	12.8	1.7
10	20	25.8	6.4	4.0	29.3	7.0	4.2	32.3	8.8	3.7
	25	24.2	6.9	3.5	27.4	7.9	3.5	31.2	9.5	3.3
	30	22.6	7.4	3.0	25.5	8.7	2.9	28.9	10.4	2.8
	35	21.1	7.9	2.7	23.6	9.3	2.5	27.5	11.3	2.4
	40	19.7	8.5	2.3	21.7	9.9	2.2	26.1	12.2	2.1
	42	19.2	8.7	2.2	21.0	10.1	2.1	25.5	12.6	2.0
	45	18.4	9.0	2.0	19.8	10.5	1.9	24.6	13.1	1.9
13	20	27.8	6.5	4.3	31.6	7.4	4.3	35.2	8.9	4.0
	25	26.2	7.1	3.7	29.7	8.1	3.7	34.0	9.8	3.5
	30	24.7	7.6	3.3	27.8	8.9	3.1	32.5	10.7	3.0
	35	23.2	8.1	2.8	25.8	9.5	2.7	30.7	11.6	2.6
	40	21.7	8.7	2.5	23.9	10.2	2.4	28.8	12.5	2.3
	42	21.2	8.9	2.4	23.1	10.4	2.2	28.1	12.9	2.2
	45	20.3	9.3	2.2	22.0	10.8	2.0	27.0	13.5	2.0
15	20	29.1	6.6	4.4	33.9	7.7	4.4	37.1	8.9	4.2
	25	27.6	7.2	3.9	32.0	8.4	3.8	36.0	9.9	3.6
	30	26.1	7.7	3.4	30.0	9.1	3.3	34.9	11.0	3.2
	35	24.5	8.3	3.0	28.0	9.8	2.9	32.8	11.8	2.8
	40	23.1	8.8	2.6	26.1	10.4	2.5	30.7	12.8	2.4
	42	22.5	9.1	2.5	25.3	10.7	2.4	29.8	13.2	2.3
	45	21.6	9.4	2.3	24.1	11.1	2.2	28.5	13.7	2.1
18	20	31.2	6.7	4.6	36.1	7.6	4.8	41.3	9.5	4.4
	25	29.6	7.3	4.1	34.2	8.4	4.1	39.2	10.3	3.8
	30	28.1	7.9	3.6	32.3	9.2	3.5	37.3	11.3	3.3
	35	26.6	8.5	3.1	30.3	10.0	3.0	35.5	12.3	2.9
	40	25.1	9.1	2.8	28.4	10.8	2.6	33.7	13.3	2.5
	42	24.4	9.3	2.6	27.6	11.1	2.5	32.9	13.7	2.4
	45	23.5	9.6	2.4	26.4	11.6	2.3	31.8	14.3	2.2
20	20	32.9	6.9	4.8	38.4	8.1	4.7	46.2	9.5	4.9
	25	31.3	7.5	4.2	36.2	8.8	4.1	43.5	10.5	4.1
	30	29.7	8.1	3.7	33.9	9.5	3.6	40.7	11.5	3.5
	35	28.2	8.6	3.3	31.6	10.1	3.1	37.9	12.6	3.0
	40	26.6	9.2	2.9	29.7	10.9	2.7	35.2	13.6	2.6
	42	25.9	9.5	2.7	28.9	11.2	2.6	34.0	14.0	2.4
	45	25.0	9.8	2.6	27.7	11.5	2.4	32.4	14.6	2.2
22	20	34.7	7.1	4.9	38.8	8.2	4.8	47.8	9.5	5.0
	25	33.0	7.7	4.3	36.8	8.9	4.2	45.3	10.6	4.3
	30	31.4	8.2	3.8	34.9	9.6	3.7	42.9	11.7	3.7
	35	29.7	8.8	3.4	32.9	10.3	3.2	40.4	12.8	3.2
	40	28.1	9.4	3.0	31.0	10.9	2.8	37.9	13.9	2.7
	42	27.4	9.6	2.9	30.2	11.2	2.7	36.9	14.3	2.6
	45	26.4	10.0	2.7	29.0	11.6	2.5	35.4	15.0	2.4

t_{VL} = cooling water flow temperature (°C)

t_Q = source temperature (°C)

Q_k = cooling capacity at full load (kW), measured in accordance with standard EN 14511

P = power consumption of the overall unit (kW)

EER = Energy Efficiency Ratio for the overall unit in accordance with standard EN 14511

Observe daily power interruptions!
see "Engineering heat pumps general"

Belaria® twin I (20-30), Belaria® twin IR (20-30)
(Dimensions in mm)

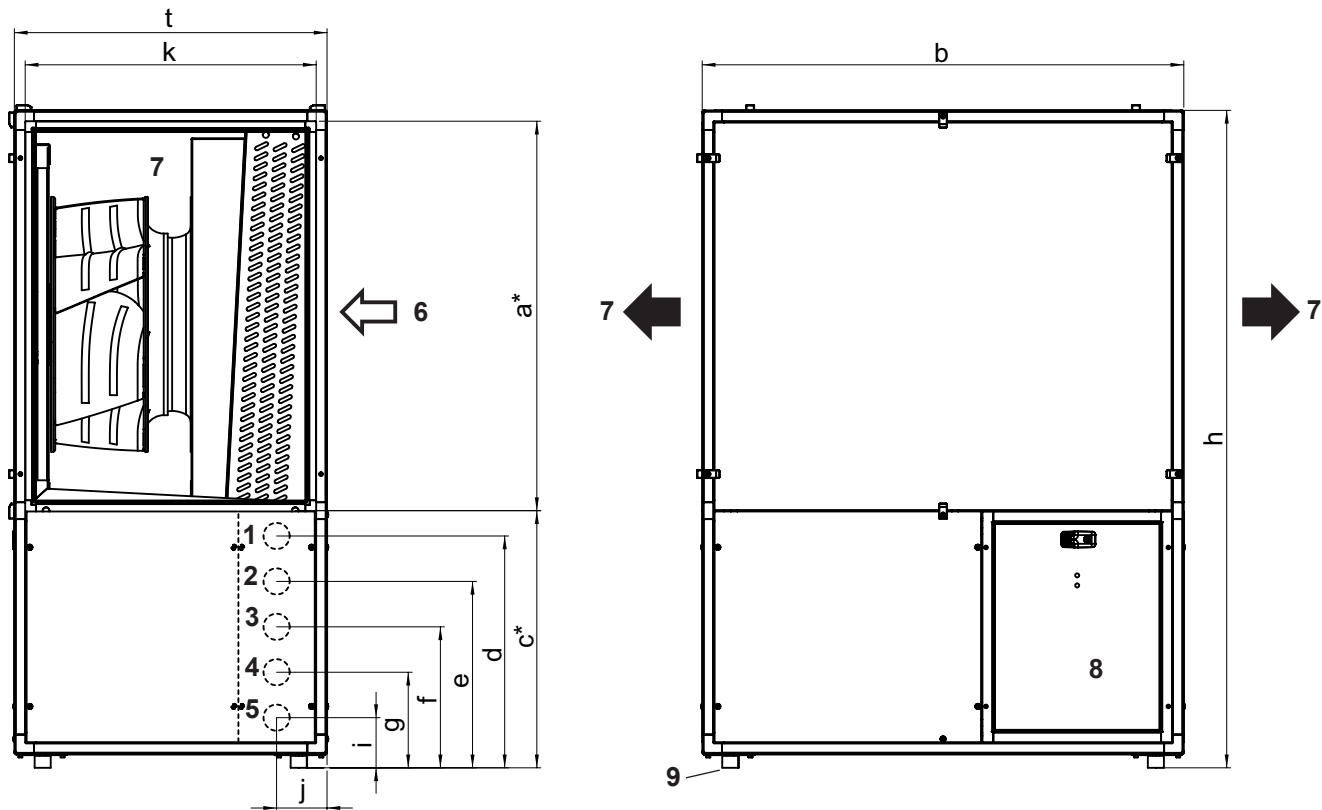

- 1 Heating flow with flexible connection hose
Belaria® twin I, Belaria® twin IR (20): R 1¼";
Belaria® twin I, Belaria® twin IR (25,30): R 1½"
- 2 For sensor/control lines
- 3 For sensor/control lines
- 4 Heating return with flexible connection hose
Belaria® twin I, Belaria® twin IR (20): R 1¼";
Belaria® twin I, Belaria® twin IR (25,30): R 1½"
- 5 Condensate drain with flexible connection hose 1".
An airtight siphon with a minimum height of 100 mm
must be installed in the condensate line on site!

- 6 Air intake (evaporator inlet)
Connection directly on the plastic frame (2 mm thick)
- 7 Air exhaust opening, panels removable
Exhaust directions: optionally towards the left or right side
(repositioning on-site)
Accessories for "Flex" indoor installation:
Exhaust panel with air hose connection plate.
- 8 Electrical box and terminal box/TopTronic® E controller
and operating switch
- 9 Adjustable feet, see dimension h ± 8 mm
(Axis dimension from outside 90 mm)
- Level heat pump horizontally

**Belaria® twin I,
Belaria® twin IR**

	b	h	a	c	d	e	f	g	i	j	k	t
(20)	1200	1735	965	740	675	540	400	260	125	125	820	880
(25,30)	1300	1935	1165	740	675	540	400	260	125	125	920	980

* Dimensions of the divided version of the Belaria® twin I, twin IR (20-30) (only available in Switzerland)

Space requirement “standard” installation with wall insulation MI

“Standard” installation with wall insulation MI

Installation in the corner of the boiler room, directly on the outer wall, with wall connection element and weatherproof grille. Intake at the back, exhaust to the right (preferred) or to the left. Water connections on the opposite side.

Cut-outs

The cut-outs must be created professionally and without cold bridges! The dimensions of the cut-outs are “clear dimensions” measured from the finished floor!

Air ducts

Concrete ducts have unfavourable acoustic properties and often magnify sound emissions. It is therefore advisable to equip the air ducts with a sound-absorbing, weatherproof lining. The air ducts must be drained.

Exhaust to the right

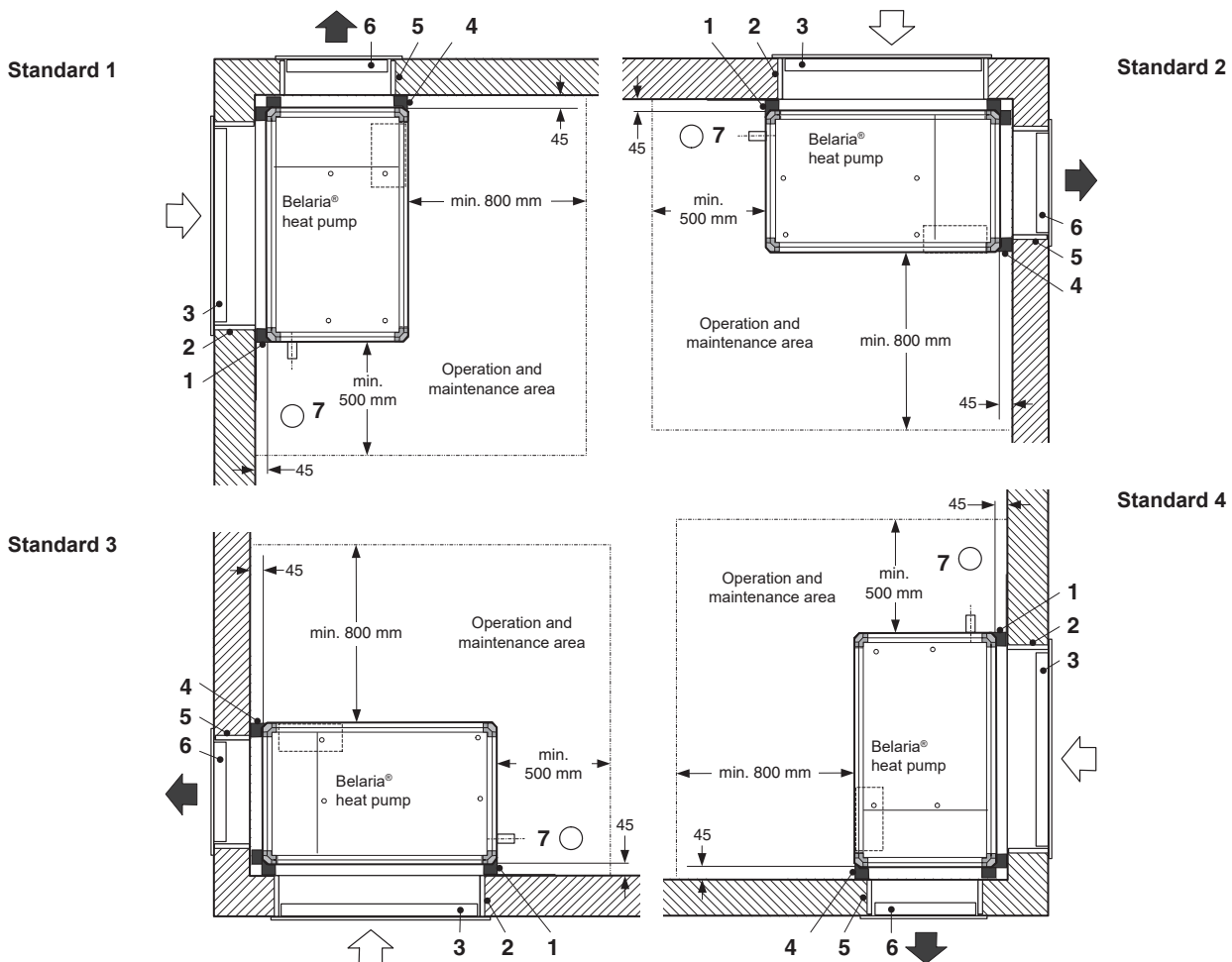

Belaria® twin I (20-30), Belaria® twin IR (20-30)

Application

Accessories type

Heat pump

Indoor installation

1	Wall connection element	Intake	WAE1
2	Wall insulation	Intake	MI1
3	Weatherproof grille	Intake	WG1
3	Weatherproof grille sound-insulated	Intake	WG1
4	Wall connection element	Exhaust	WAE2
5	Wall insulation	Exhaust	MI2
6	Weatherproof grille	Exhaust	WG2
6	Weatherproof grille sound-insulated	Exhaust	WG2
7	Condensate drain (on site, siphon height approx. 100 mm)		

Space requirement “standard” installation with wall insulation MI

“Standard” installation with wall insulation MI

Installation in the corner of the boiler room, directly on the outer wall, with wall connection element and weatherproof grille. Intake at the back, exhaust to the right (preferred) or to the left. Water connections on the opposite side.

Cut-outs

The cut-outs must be created professionally and without cold bridges!

The dimensions of the cut-outs are “clear dimensions” measured from the finished floor!

Air ducts

Concrete ducts have unfavourable acoustic properties and often magnify sound emissions. It is therefore advisable to equip the air ducts with a sound-absorbing, weatherproof lining. The air ducts must be drained.

The exhaust opening on the right side should be preferred as a result of accessibility for service!

Exhaust to the left

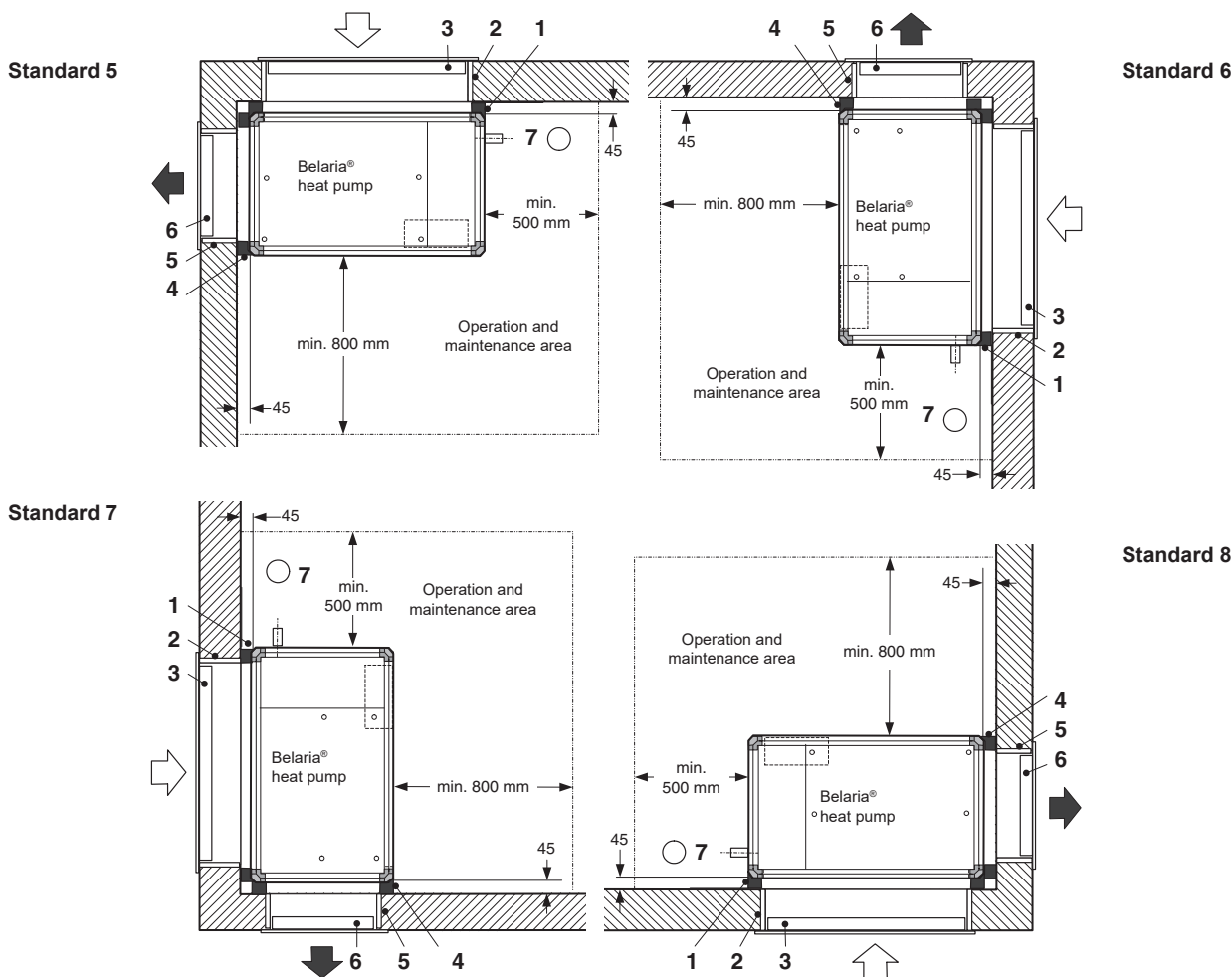

Belaria® twin I (20-30), Belaria® twin IR (20-30)

Application

Accessories type

	Application	Accessories type
Heat pump	Indoor installation	
1 Wall connection element	Intake	WAE1
2 Wall insulation	Intake	MI1
3 Weatherproof grille	Intake	WG1
3 Weatherproof grille sound-insulated	Intake	WG1
4 Wall connection element	Exhaust	WAE2
5 Wall insulation	Exhaust	MI2
6 Weatherproof grille	Exhaust	WG2
6 Weatherproof grille sound-insulated	Exhaust	WG2
7 Condensate drain (on site, siphon height approx.100 mm)		

Space requirement “standard” installation with wall insulation MI

Cut-out dimensions

“Standard” installations – heat pump in the corner, without air ducts, with wall insulation MI

(Dimensions in mm)

- The cut-outs must be created professionally.
- Cut-out dimensions from top edge of finished floor

Standard installation 1-4

Air exhaust to the right

Preferred solution due to ease of access for servicing

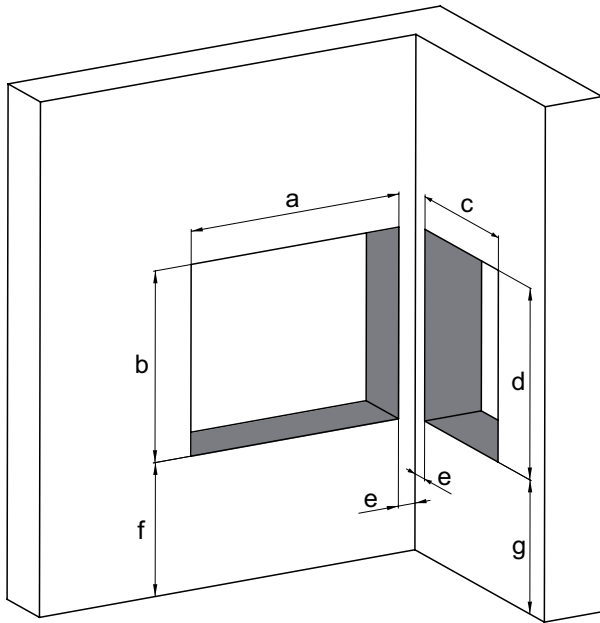

Standard installation 5-8

Air exhaust to the left

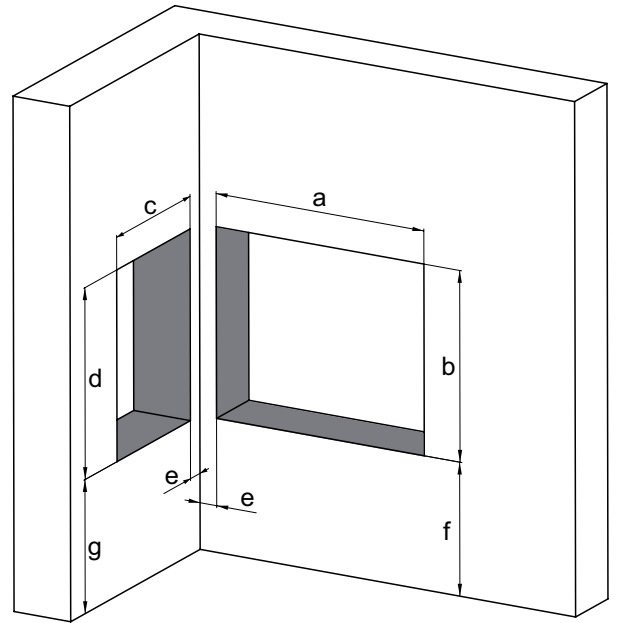

**Belaria® twin I,
Belaria® twin IR**

Cut-out dimensions

	a	b	c	d	e	f	g
(20)	1140	950	820	950	70	740	740
(25,30)	1240	1150	920	1150	70	740	740

“Standard” installation with wall insulation MI

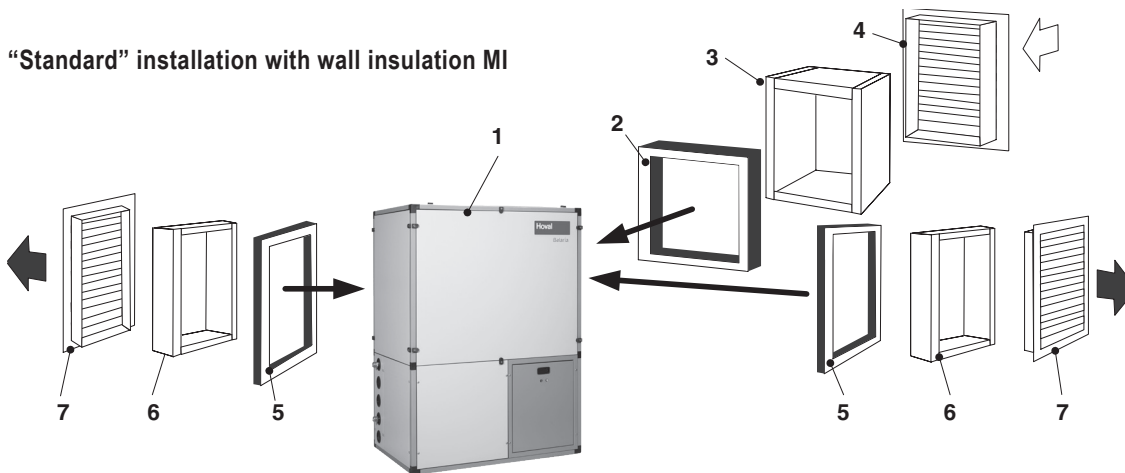

1 Heat pump

Intake

- 2 Wall connection element
- 3 Wall insulation (20 mm)
- 4 Weatherproof grille
- 4 Weatherproof grille sound-insulated

Exhaust

- 5 Wall connection element
- 6 Wall insulation (20 mm)
- 7 Weatherproof grille
- 7 Weatherproof grille sound-insulated

Weatherproof grille

(Dimensions in mm)

Weatherproof grille made from aluminium with mesh grille.

For the cut-outs with wall insulation type MI-E01 (intake) or MI-A01, MI-A02 (exhaust).

If the thermal insulation for the wall openings is provided on-site, it must be 20 mm thick!

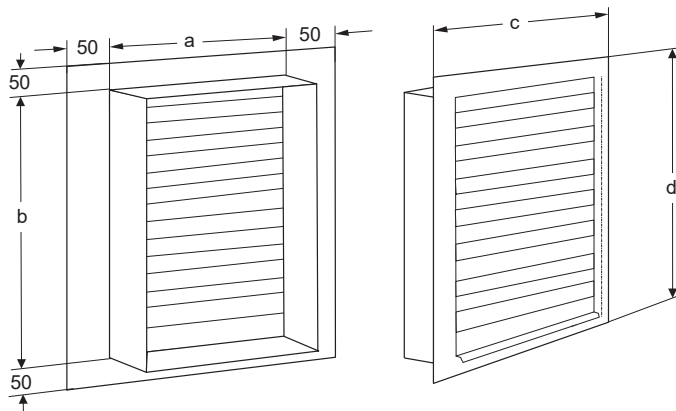

Weatherproof grille type	Belaria® twin I, Belaria® twin IR type	Application for	a	b	c	d
WG1	(20)	Intake	1100	900	1180	1000
WG1	(25,30)	Intake	1200	1100	1280	1200
WG2	(20)	Exhaust	780	900	860	1000
WG2	(25,30)	Exhaust	880	1100	960	1200

Clear dimensions Belaria® twin I (20), Belaria® twin IR (20)
 (Dimensions in mm)

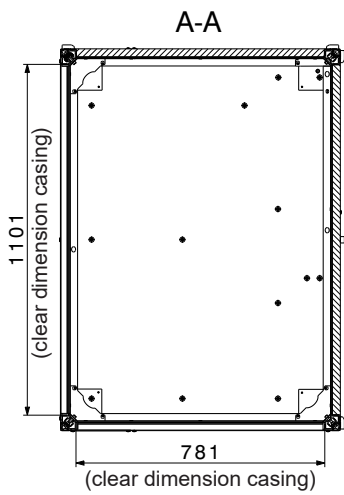
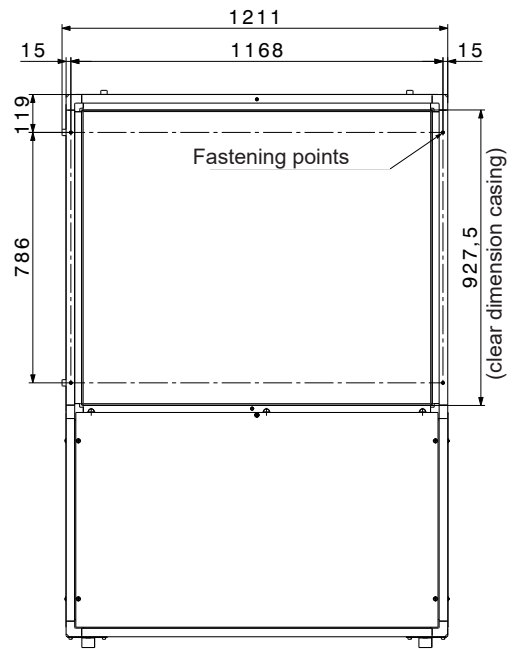
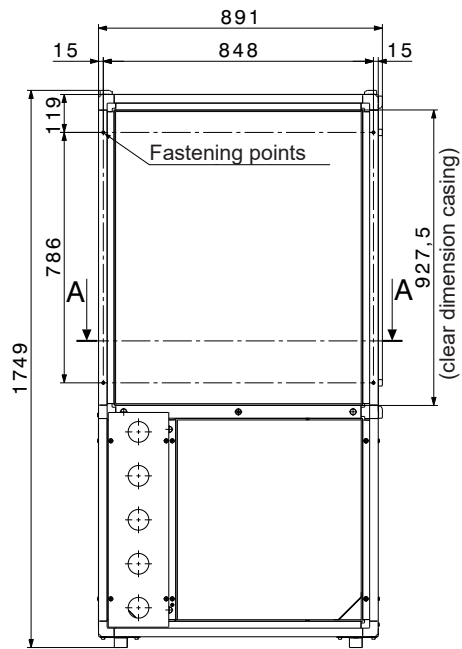

Clear dimensions Belaria® twin I (25,30), Belaria® twin IR (25,30)
 (Dimensions in mm)

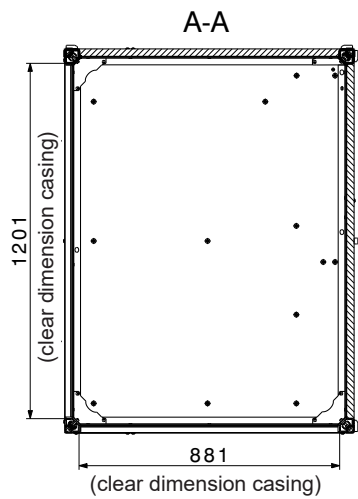
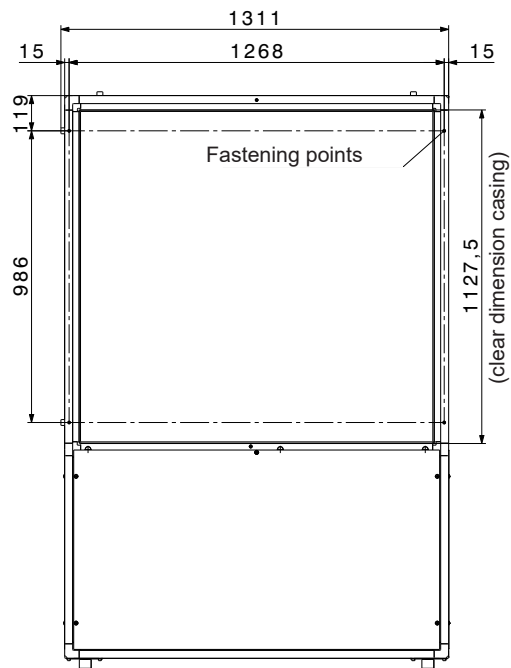
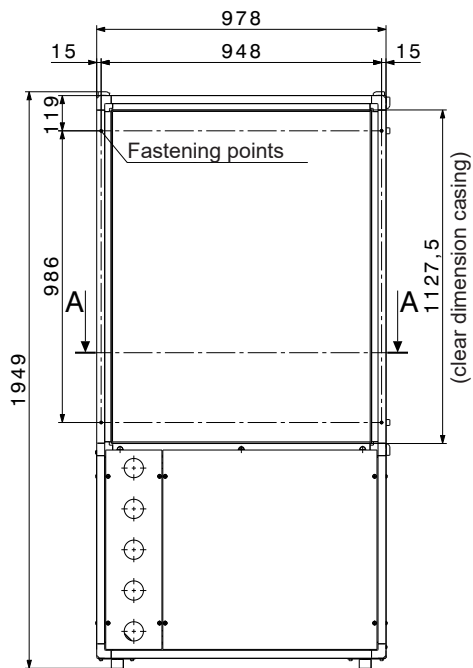

Requirements and directives

The following requirements and directives must be complied with:

- Technical information and assembly instructions from Hoval
- Hydraulic regulations and those pertaining to instrumentation and control
- Building regulations
- Fire protection regulations
- Regulations of the local power station
- VDI 4640: Thermal use of the underground
- DIN EN 1736: Refrigerating systems and heat pumps
- DIN EN 378: Refrigerating systems and heat pumps – Safety and environmental requirements
- DIN EN 13313: Refrigerating systems and heat pumps – Competence of personnel
- VDI Directive 2035: Protection against corrosion and boiler scale in heating and domestic hot water systems.
- EN 12828: Heating systems in buildings – Design of hot water heating systems
- EN 12831: Heating systems in buildings – Method for calculation of the design heat load
- EN 15450: Heating systems in buildings – Design of heat pump heating systems

Switzerland:

Environment

- Chemical risk reduction ordinance (CRRV), Appendix 2.10 ff
- Instructions for using heat from water and ground (Buwal)
- Instructions for using heat with closed geothermal probes (Buwal)
- Noise abatement regulations (LSV)
- SN 253 120 (refrigerant definitions)
- Cantonal and local regulations
- SIA 384/1: Heating systems in buildings

Electrical connection

- VSE recommendations for connecting heat pump systems for heating and domestic water heating to the network of electricity companies (2.29d, September 1983)
- Regulations of the local power station
- Do not attach any rigid connections (e.g. cable duct) to the heat pump casing

Planning and design

- Cantonal and local fire prevention authority regulations as well as state-specific regulations
- SWKI directive 92-1 hydraulic circuit of heat pump heating systems
- FWS and GKS regulations and codes of practice
- SWKI HE301-01 guidelines "Safety engineering installations for heating systems"
- Bivalent systems: special engineering guidelines for the corresponding supplementary heat generator must be observed
- SIA 384/6 Geothermal probes

Austria:

Environment

- ÖWAV code of practice 207: Thermal use of underground water and the underground – heating and cooling
- ÖNORM S 5021: Basic acoustical principles for town, regional and physical planning
- ÖAL Directive no. 3: Assessment of noise emissions in the neighbouring area

Electrical connection

- Country-specific and regional regulations and laws, in particular ÖVE directives

Planning and design

- OIB Directive no. 4: Safety in use and barrier-free access
- ÖNORM B3417: Safety equipment for roofs
- ÖNORM H 12828: Design of hot water central heating systems with or without water heating
- ÖNORM H 5195-1 and -2: Heat transfer media for building services systems
- ÖNORM M 7755: Heat pump heating systems

Germany:

Environment

- DIN 8901: Refrigerating systems and heat pumps – Protection of soil, ground and surface water
- TA-Lärm: Requirements on the installation location
- LAI acoustic guidelines
- ISO 9613-2

Electrical connection

- VDE directives
- Technical connection condition (TAB 2019) for connecting to the low voltage grid
- DIN 8947: Heat pumps; heat pump units with electric driven compressors for heating of water
- §14a Energy Industry Act: Grid-serving connection (operation as controllable consumption appliance)

Planning and design

- Building Energy Act GEG
- Drinking Water Ordinance (TrinkwV)
- DVGW worksheets W 551 and W 553
- DIN EN 15450: Heating systems in buildings – Design of heat pump heating systems
- VDI 4640
- VDI 4650
- VDI 6044 Heating water
- VDI 4645 Heating systems in buildings – Design of heat pump heating systems

Buffer storage tank

A buffer storage tank ensures optimal operating conditions for the heat pump.

- Hydraulic decoupling of the various volumetric flows from the heat pump and heat distribution system (heating)
- Absorbs the power reserves of the heat pump and reduces the switch-on frequency (cycling)
- Allows several heating circuits to be connected

A buffer storage tank is mandatory for Hoval air/water heat pumps (defrost energy).

A buffer storage tank can be dispensed with if a direct heating or cooling circuit with storage capacity is involved, and there is always a constant flow rate ($\frac{2}{3}$ must be unblockable).

For Hoval heat pumps, the following minimum sizes of the buffer storage tank (EnerVal) must be observed. The minimum running times of the heat pumps are taken into account. For air/water heat pumps, the energy required for defrosting the heat pump is included.

The volumes for power company off-periods shall be added on a project-by-project basis in accordance with local regulations.

Recommended minimum sizes of buffer storage tank

	EnerVal type	DuoVal E/C (100/300)		EnerVal type	DuoVal E/C (100/300)
UltraSource® B comfort C (8)	100	•	UltraSource® T comfort (8)	100	•
UltraSource® B compact C (8/200)	100		UltraSource® T compact (8/200)	100	
UltraSource® B comfort C (11)	100	•	UltraSource® T comfort (13)	100	•
UltraSource® B compact C (11/200)	100		UltraSource® T compact (13/200)	100	
UltraSource® B comfort C (17)	300		UltraSource® T comfort (17)	200	
Belaria® pro comfort (8)	100	•	Thermalia® comfort (8)	300	
Belaria® pro comfort (13)	100	•	Thermalia® comfort (10)	500	
Belaria® pro comfort (15)	300		Thermalia® comfort (13)	500	
Belaria® pro (20)	500		Thermalia® comfort (17)	800	
Belaria® pro (25)	500		Thermalia® comfort H (7)	300	
Belaria® pro (40)	1000		Thermalia® comfort H (13)	500	
Belaria® pro (50)	1000		Thermalia® twin (20)	500	
Belaria® comfort ICM (8)	100	•	Thermalia® twin (26)	500	
Belaria® comfort ICM (13)	100	•	Thermalia® twin (36)	800	
Belaria® twin I/IR (20)	500		Thermalia® twin (42)	1000	
Belaria® twin I/IR (25)	500		Thermalia® twin H (13)	300	
Belaria® twin I/IR (30)	800		Thermalia® twin H (19)	300	
Daikin Altherma (14)	100	•	Thermalia® twin H (22)	500	
Daikin Altherma (18)	100	•	Thermalia® dual (55)	1500	
Belaria® fit (8)	300		Thermalia® dual (70)	1500	
Belaria® fit (13)	500		Thermalia® dual (85)	2000	
Belaria® fit (20)	800		Thermalia® dual (110)	1500 + 1000	
Belaria® fit (26)	1000		Thermalia® dual (140)	1500 + 1500	
Belaria® fit (40)	2000		Thermalia® dual H (35)	800	
Belaria® fit (53)	2000		Thermalia® dual H (50)	1000	
Belaria® fit (70)	1500 + 1500		Thermalia® dual H (70)	1500	
			Thermalia® dual H (90)	2000	
			Thermalia® dual R (55)	1500	
			Thermalia® dual R (70)	1500	
			Thermalia® dual R (85)	2000	
			Thermalia® dual R (110)	1500 + 1000	
			Thermalia® dual R (140)	1500 + 1500	

Notice

Check the availability of the respective units in different countries

Off-periods by power companies

If the power supply for the heat pump is temporarily shut down by the power company (for example due to special tariffs), this has to be taken into account in the design of the heat pump. The daily heat quantity must then be produced when electricity is available. The heat pump must be designed for the maximum off-period in accordance with the energy supply contract.

With radiator heating systems, the loss of radiant heat if the electricity is switched off by the energy company is seen as a nuisance, even though the room temperature may not in fact drop significantly. This must be taken into consideration in the design process. A larger buffer storage tank can only bring a limited improvement as with a heat pump, the temperature elevation is kept to a minimum for a better COP.

The volumes for power company off-periods shall be added to the minimum sizes of the buffer storage tanks on a project-by-project basis in accordance with local regulations.

Set-up

In the case of floating screed or underlay, a recess should be cut in the screed and the impact sound insulation around the heat pump.

- The installation location must be selected in accordance with the valid requirements and directives. Rooms with high air humidity, for example laundry rooms, etc. are not suitable installation locations (dewpoint < 10 °C)
- The heat pumps installed inside can be mounted on the floor in the boiler room
- The installation location must be free from dust or other foreign matter which could lead to contamination
- Access for the purpose of operation and maintenance must be ensured
- Penetrations and openings in the masonry must be created proficiently (cold bridges, etc. on the outside wall must be avoided at all costs)
- Concrete shafts and light wells by means of which the air is drawn in or blown out must be provided with drainage
- If the ambient temperature of the heat pump is less than 10 °C, it must be equipped with a crankcase heater for each compressor. This applies to heat pumps whether they are set up indoors or outdoors

Indoors

- **Where possible, the installation location should be outside noise-sensitive areas of the building and equipped with a sound-absorbing door**
- Access for the purpose of operation and maintenance must be ensured
- The installation room must be frost-free
- The space around the indoor unit must allow for adequate air circulation
- If water is discharged through the safety valve, precautions must be taken to ensure that this water is drained away
- The indoor unit is not allowed to be installed where there could be a potentially explosive atmosphere

- The heat pump must not be installed in a room that is also used as a workplace or workshop. If construction work which generates a lot of dust is carried out in the installation room of the heat pump, the unit must be switched off and covered
- If the noise level is measured under the actual installation conditions, this will be higher than specified in the unit specification. This is because of reflected noise from the surroundings
- Take precautions so that no damage can be caused by leaking water if there is a leak at the installation location and in the vicinity
- The floor must withstand the weight of the indoor unit. It must be level so that no vibration and noise is created and the unit stands securely
- Do not place objects on the unit
- Do not climb onto, sit on or stand on the unit
- Make sure that adequate precautions are or will be taken according to the particular local and national regulations in the event that there is a leak in the refrigerant circuit

It is imperative that a sludge separator is installed in the heating return upstream from the heat pump.

Outdoors

The outdoor unit is installed outdoors. The installation location must be selected carefully. It is essential that the following ancillary conditions are met:

- The subsoil in the installation location must be sufficiently stable to bear the weight of the unit and its vibration in operation
- The location must have adequate space for installation, maintenance and cleaning of the unit (see "Dimensions/Space requirements")
- As condensate flows out of the outdoor unit, a gravel bed to absorb the condensate must be installed under it. Do not place anything under the outdoor unit that is sensitive to moisture
- Due to the sound emissions, the installation location should not be beneath living-room or bedroom windows and be far enough away from neighbouring buildings (perform calculation)
- The selected location should be such that the air blown out by the unit does not bother occupants of the building or neighbours
- No parts and systems at risk of frost damage are allowed to be on the exhaust side
- It is essential to avoid air short-circuiting. The space necessary for intake and exhaust must always be provided (see "Space required")
- The installation location must be selected so that the air intake and exhaust are not blocked or obstructed by snow, leaves, etc.
- Installation in wall niches is not recommended (air short circuit, sound reflection)
- Several units must not be installed directly one above the other
- Install the units, the mains cables and the branch wiring at least 3 m away from TV sets and radios. This should prevent interference with picture and sound

- The intake air must be completely free of aggressive substances such as ammonia, sulphur, chlorine etc.
- Install the outdoor unit so that the intake side faces the wall and is not directly exposed to the wind
- Never install the outdoor unit in a place where the intake side is directly exposed to the wind
- The outdoor unit must be protected from heavy snowfall
- Install the unit at sufficient height above the ground to ensure that the unit is not covered by snow and freezing condensate cannot impair operation (see separate base plans)

Sound emissions

Indoor installation

The effective sound pressure level in the installation room depends on various factors such as room size, absorption capacity, reflection, free sound propagation, etc. For this reason, it is important to ensure that where possible, the boiler room is outside noise-sensitive areas of the building and equipped with a sound-absorbing door.

If air/water heat pumps are set up indoors, the intake and exhaust air openings or the installation location must be selected so that the sound emissions are not perceived as a disruptive. The openings in the masonry for intake and exhaust air or the installation location must be made in the less frequented area of the building (not below or adjacent to living rooms and bedrooms).

Air ducts made of concrete have unfavourable acoustic properties and often magnify noise emissions. It is therefore advisable to equip the air ducts with a sound-absorbing, weatherproof lining or with sound attenuation splitters.

Outdoor installation

When air/water heat pumps are set up outdoors, optimum planning of the installation location is particularly important, since the noise not only affects the building in question but also often adjacent buildings or properties. The installation location must be selected so that there are no living rooms and bedrooms in the noise emission area. In many cases, selecting the set-up location on the "noisy side" facing the road or street has proven to be ideal.

When it comes to noise emissions, local conditions and individual noise sensitivity play a significant role, which means it is recommended for a specialist (acoustic engineer) to be consulted with regard to finding a solution. No rigid connections (e.g. cable ducts) are allowed to be attached to heat pumps, in order to avoid solid-borne noise.

Design of the heat source

An earthbound heat source (flat collector, depth probe) must be designed for the total energy requirement. The total energy requirement is the sum of the energy requirements for room heating, water heating and, where applicable, special applications.

Hot water supply

If the domestic hot water is heated using the heating heat pump, this must be taken into account when designing the heat pump.

One and two-family home:

0.25 kW per person needs to be added to the heat output. This corresponds to a domestic hot water requirement of about 50 litres at 45 °C per day.

Multi-family home:

In the multi-family home, the design is carried out according to DIN EN 15450 taking account of the hygiene requirements as stated in the Drinking Water Ordinance as well as DVGW worksheets W 551 and W 553. Accordingly, it is first necessary to calculate the maximum domestic hot water requirement and the consumption behaviour. As a rule of thumb, a daily average domestic hot water requirement of 1.45 kWh per person can be assumed. At a storage temperature of 60 °C, this corresponds to a water quantity of 25 l per person.

In the case of increased domestic hot water requirement (large tubs, monsoon showers, etc.) the required bulk output and the daily domestic hot water requirement must be calculated and taken into consideration when dimensioning the heat pump or heat source.

Ideally, calorifiers with large inlying plain tube heat exchangers (CombiVal ESR and ESSR) are used.

The maximum heat output of the heat pump is decisive for setting the size of the heat exchanger surface area:

- Heat exchanger surface area = 0.3-0.4 m² per kW max. heat pump heat output during the operating time of the system (air/water heat pumps with A20/W55)
- In 2-stage heat pumps, the output of the first stage can be used

Power requirement for special applications

If the heat pump is also used, for example, to heat swimming pools, it is important to take the greatly increased energy requirement into consideration in the design phase.

In the case of an outdoor swimming pool which is only heated outside the heating season, the increased annual runtimes mean that the heat source needs to be correspondingly enlarged (only for geothermal heat).

If an indoor swimming pool is heated all year round, the required output for room heating and heating of the water in the pool must be added to the total output, in addition to the increased runtime.

Installation

The system must be filled in accordance with the applicable standards.

Where copper is used as an installation material, damage to the rubber tubes used with heat pumps to reduce the structure-borne sound level may occur. As an alternative, corrugated stainless steel tubing can be used (on site). However, such pipes bring less reduction of structure-borne sound.

An air separator must be installed in the flow pipe.

A sludge separator must be installed in the return line to the heat pump.

Baking out

The baking out of buildings and floors (underlays) must not be done with Hoval heat pumps. If this instruction is not observed, the additional load can lead to irreparable damage to the heat source. Failure to do so may result in losses of guarantee/warranty. Alternative heat sources should thus be used for the baking out.

However, mobile heaters running on electricity, oil or gas can also be used.

Operating modes

Monovalent:

As a stand-alone heat generator, the heat pump covers all heat demands at all times. For the monovalent operating mode, ensure that the maximum achievable flow temperature of the heat pump is greater than the maximum required flow temperature of the heating.

Bivalent parallel and single energy source:

The heat pump alone heats until the switch-on point (bivalent point) is reached. An additional heat generator then heats the water in parallel to this. If this additional heat generator is an electric heating element, then the operating mode is monoenergetic. For a bivalent parallel operating mode, ensure that the maximum achievable flow temperature of the heat pump is greater than the maximum required flow temperature of the heater.

Bivalent alternative:

The heat pump alone heats until the switching point (bivalent point) is reached. An additional heat generator then heats the water alone. For the alternative bivalent operating mode, ensure that the maximum achievable flow temperature of the heat pump is greater than the maximum flow temperature of the heater. Higher temperatures are thereafter possible with the additional heat generator.

Bivalent semi-parallel:

The heat pump alone heats until the switch-on point (bivalent point) is reached. An additional heat generator then heats in parallel to this until the switch-off point of the heat pump. The heat pump can be switched off in this case either based on efficiency or energy cost criteria, taking account of the necessary flow temperature.

Performance data

The standard points for specifying the relevant values are clearly defined. The following conditions apply to heat pump systems:

Air/water A2W35

Brine/water B0W35

Water/water W10/W35

Heat source:

- A2 = air inlet temperature 2 °C
- B0 = brine inlet temperature 0 °C
- W10 = water inlet temperature 10 °C

Heat utilisation (heating):

- W35 = water outlet temperature 35 °C

Electrical data

The grid operators require the following information in order to grant approval:

I _{max} (A)	= max. current consumption of the heat pump. Used for setting the dimensions of the feeder cable and fusing.
Starting current (A)	= current consumption on direct starting with external starting current limiter
cos φ	= power factor; used for setting the dimensions of any power factor correction

This information specific to heat pumps is listed for the specific products in the Hoval catalogue and on the heat pump rating plate.

Switzerland:

The required clarifications and the approval request must be made during the planning phase of the system. The approval of the responsible grid operator must have already been obtained when the heat pump is ordered!

If the inrush current exceeds the maximum values defined by the grid operator (system), a frequency converter must be supplied or installed by the client.

Water quality in heating systems

Filling and replacement water, heating water

The following applies:

- For Germany VDI 2035
- For Austria ÖNORM H5195
- In addition, the EN 14868 standard must be applied, **as well as the manufacturer-specific specifications**

Manufacturer-specific specifications

Filling and replacement water

The filling and replacement water can be both fully demineralised and also merely softened.

Heating water

- In the case of full demineralisation of the filling and replacement water, the electrical conductivity of the heating water must not exceed the value of 100 $\mu\text{S}/\text{cm}$.
- In the case of softening the filling and replacement water, the following conditions must be complied with:
 - Electrical conductivity of the heating water for operation with water containing salts: $> 100 \mu\text{S}/\text{cm}$ to $\leq 1500 \mu\text{S}/\text{cm}$
 - pH value of the heating water for systems without aluminium alloy as water-side material 8.2 to 10.0 (measurement 10 weeks after commissioning at the earliest)
- The sum of the chloride, nitrate and sulphate contents in the heating water must not exceed 50 mg/l in total.

Additional notices

- Hoval heat pumps and calorifiers are suitable for heating systems without significant oxygen intake (system type I in accordance with EN 14868.)
- Systems with continual oxygen intake (e.g. underfloor heating without diffusion-proof plastic piping) or intermittent oxygen intake (e.g. requiring frequent topping-up) must be equipped with a system separation.
- If only the heat pump is replaced in an existing system, it is not recommended for the entire heating system to be refilled, provided that the heating water already contained in the system complies with the relevant directives or standards.
- Before filling new systems and, where necessary, existing heating systems containing heating water that does not comply with the directives or standards, the heating system must be professionally cleaned and flushed. The heat pump must not be filled until the heating system has been flushed.

Water composition

Water quality

Heating water:

- The requirements of European standard EN 14868 and the SWKI directive BT 102-01 must be met
- Hoval heat generators are suitable for heating systems without significant oxygen intake (system type I in accordance with EN 14868)
- Systems with
 - **continuous** oxygen intake (e.g. under-floor heating systems without diffusion-proof plastic piping) or
 - **intermittent** oxygen intake (e.g. requiring frequent topping-up)must be equipped with **separate circuits**
- Treated heating water must be tested at least once every year, or more frequently if specified by the manufacturer of the inhibitor
- In the case of existing systems (e.g. replacing the heat generator), if the water quality of the existing heating water meets the requirements of BT 102-01, re-filling the system is not recommended
- Before filling new systems and, where necessary, existing systems, the heating system must be professionally cleaned and flushed! The heat generator must not be filled until the heating system has been flushed
- Parts of the heat generator/calorifier which come into contact with water are made of copper and stainless steel
- The pH value of the heating water should be between 8.2 and 10.0 after 6-12 weeks of heating operation to avoid obstruction of the flow as a result of deposits of corrosion products from other heating system materials

Filling and replacement water:

- As a rule, the best filling and replacement water for a system with Hoval heat generator is untreated domestic water. The requirements of EN 14868 must be met in this context
- To maintain the high efficiency of the heat generator, the water content of the system and the maximum flow temperature should not exceed the values in the tables, based on the output of the heat generator (smallest heat generator for systems with more than one heat generator)
- The total quantity of filling and replacement water added to the heat generator over its service life must not be higher than three times the system water content
- SWKI BT 102-01 applies to the protection of the heating system, and it makes the exact specifications for the filling water quality.

Engineering checklist for heat pump systems

- Definition of hydraulic diagram according to Hoval standard for heating, possibly hot water and cooling
- Dimensions of heat pump type selected according to Qh, flow temperature and operating method and application limits (tables/heat output curves/bivalence point)
- Define minimum size of buffer storage tank
- Observe placement and bringing in possibility of heat pump, buffer storage tank and calorifier
- Configuration of calorifier with corresponding size and required heat register size according to table
- Clarification of electrical supply with energy supply company (conditions/off-periods/connected load)
- Clarification of subsidy amounts and ancillary conditions

Air/water heat pumps

Split version

- Installation location of outdoor unit/position: air exhaust and intake must be clear
- No parts and systems at risk of frost damage are allowed to be on the exhaust side
- The necessary clearance (see "Dimensions/space required") and accessibility must be assured
- Noise development requires minimum distances from sensitive rooms in adjacent buildings. These must be complied with (country-specific requirements)
- There must be a condensate drain for the outdoor unit
- The indoor unit must be positioned so the necessary clearances are complied with
- Pipes (refrigerant) must be routed in accordance with the specifications in the installation instructions
- Avoid direct connection to the heating network, and if this is not possible, then only by differential pressure relief valve (minimum flow rate) and intermediate tank (minimum water volume)
- Possible selection of type with cooling function
- Cooling with fan convectors (caution: condensate drain for fan convectors)

Brine/water heat pumps

Clarification of heat source

- Installation location (not under bedroom)
- Dimensioning of geothermal probe/flat collector (domestic hot water supplement/number of probes/pressure drop calculation (aim for minimum current consumption of brine pump))

Air/water heat pumps

Monoblock

- Installation location (indoor or outdoor). Air exhaust and intake must be clear. Comply with notes on air guidance
- No parts and systems at risk of frost damage are allowed to be on the exhaust side
- The necessary clearance (see "Dimensions/space required") and accessibility must be assured
- Noise development (not under bedrooms)
- Noise development requires minimum distances from sensitive rooms in adjacent buildings. These must be complied with (country-specific requirements). Provide damping measures if required
- There must be a condensate drain

Ground water heat pumps

Clarification of ground water approval

- Geological water inspection report
- Ground water temperatures summer + winter/quantity in l/min or m³/h
- Installation location (not under bedroom)
- Connection of ground water only via separating heat exchanger (intermediate carrier circuit). Separating heat exchanger is configured according to the heat pump type (table). Caution: intermediate carrier circuit: read out heat output and flow temperature at brine/water 7 °C)
- Design of ground source heat pump and possible intermediate circuit pump according to nominal flow rates and pressure drops
- The intermediate circuit is filled with frost protection agent for frost protection of -15 °C

Notice

In ground water applications, the ground water pump (submersible pump) cannot be directly connected in the heat pump. Here, corresponding connections must be provided on site.

Version and commissioning

Clarify which installation location and which system concept are provided, and contact Hoval in case anything is unclear.

Checks before installation

The following checks are required before installation:

- Consult the installation, operating and maintenance instructions of the Hoval heat pumps
- Access for the purpose of operation and maintenance
- Dimensions and position of the masonry openings
- Position of heating connections and condensate drain
- Position of the condensate drain
- Drainage of the air ducts or set-up area for the heat pump and acoustic insulation of the air ducts
- Setting up the heat pump (clearances, minimum distances)

Hydraulics

- Check the hydraulic piping of the system according to be selected hydraulic schematic
- Clarify any open issues before installation
- The wiring diagram does not serve as a hydraulic schematic, but merely for positioning of sensors, valves, pumps and thermostats, etc.
- Fittings and instruments must be installed according to the corresponding engineering documents

Electrical installation

- The electrical connection cables to the heat pump must be installed in accordance with Hoval's and the country's specific regulations. Do not attach any rigid connections (e.g. cable duct) to the heat pump casing
- The information on the system diagram must be complied with
- Quality and routing regulations for the sensor cables must be complied with
- The low-voltage cables must be routed separately (not in the same cable duct as 230 V or 400 V cables)
- Comply with the connection requirements of the grid operator (TAB 2019)
- If a frequency converter is required (starting current), it must be supplied by the client

Checks before commissioning

The following items must be checked before notifying Hoval that the system is ready for commissioning:

- Hydraulic piping
- Positioning and installation of the instruments and fittings
- Positioning and installation of the sensors according to the corresponding wiring diagram or project diagram
- Electrical connections for heat pump, control systems, sensors, pumps, motorised valves, etc.
- Functions of the complete heat source system
- Flushing, filling and venting of the complete system

Geothermal probe systems/surface collectors

Comply with the following in geothermal probe systems that are filled with a mixture of frost protection agent and water:

- Fully demineralised water must be used
- The concentration of frost protection agent must be selected at least so as to ensure protection against frost down to $-15\text{ }^{\circ}\text{C}$ and so that the required minimum concentration stipulated by the frost protection agent manufacturer is maintained (protection against sludge formation and corrosion). However, the frost protection concentrations should be kept as low as possible with a view to improved heat transmission and lower pump output
- The frost protection agent and the water must be mixed in the required concentration prior to filling. Filling with ready-mixed solution that meets the aforementioned requirements is recommended

Caution!

The condenser and evaporator of a heat pump are sensitive to blockage, as a result of which the system must be flushed carefully on the heating and source sides before the heat pump is connected. The heat exchanger should not have any flow during the flushing procedure. The heating water must be treated according to the recommendations of the professional associations.

Hydraulic balancing/setting the flow rates

- The flow rates are calibrated by the installer. This should be based on the recommended nominal flow rate of the heat pump
- In systems with a buffer storage tank, the flow rate in the fully opened heat circuit must not be greater than the flow rate in the buffer circuit, otherwise the colder heating water return will overflow through the buffer storage tank, leading to mixed temperatures in the flow to the heating system.

Notice for commissioning

The registration form should be sent to Hoval 14 days in advance.

- The commissioning should be carried out during the heating period, the best time is during the transitional period
- Temporary electrical installations as well as systems operating in the building carcass are exposed to hazards (electrical power cuts, incorrect operation by third parties, etc.) which can lead to damage to the heat pump and the entire system
- In systems in the building carcass, it is not possible to maintain the boundary conditions such as installation location without frost risk, minimum required return temperature, etc. for the heat pump in practical terms, meaning that no correct operation is assured

Caution!

• Air/water heat pumps

The heat output of the air/water heat pump is significantly dependent on the outdoor temperature, as a result of which no commissioning activities should be undertaken at temperatures close to the freezing point (provide buffer storage tank with an electric heating element). The heat pump is not allowed to be used in the building carcass for drying out of the structure or for routing underfloor heating pipes (provide buffer storage tank with an electric heating element for example). Split pipes can only be evacuated properly at a temperature above $8\text{ }^{\circ}\text{C}$, as a result of which the equipment room must have a room temperature of at least $15\text{ }^{\circ}\text{C}$. Due to the risk of moisture entering the refrigeration circuit, the outdoor unit cannot be connected in rainy weather. During commissioning, the room temperature of the heated rooms must be at least $15\text{ }^{\circ}\text{C}$. If a buffer storage tank is provided, its heating water temperature is not allowed to be less than $17\text{ }^{\circ}\text{C}$ during commissioning.

• Brine/water heat pumps

The brine/water heat pumps with geothermal probes as the heat source are not suitable for drying out the building carcass or for laying underfloor heating pipes, due to the output/load mixing ratio. The long running times of the heat pump can lead to excessive use of the geothermal probes and thus long-term damage as well as a lower utilisation temperature and even the establishment of permafrost. On commissioning, the technical room should have a temperature of more than $15\text{ }^{\circ}\text{C}$ and the return temperature should be at least $12\text{ }^{\circ}\text{C}$.

Commissioning

It is used for checking and setting the definitive operating values of the system as well as for instructing the operating personnel.

During commissioning, the engineering set-points of the system must be known, and the following persons must be present:

- The installer to inspect the heating-side installation
- The electrician to inspect the electrical installation
- Hoval Service
- The building owner or the person responsible for operation. Hoval service only prepares the commissioning protocol of the heat pump or the system parts supplied by Hoval. The operating instructions for the Hoval heat pumps and the accessories supplied by Hoval are delivered with the articles or handed over during commissioning.

Caution!

If Hoval is required to undertake commissioning in uninhabited building carcasses without the required general conditions and proficiently undertaken electrical and heating installation of the system incl. bleeding, Hoval will not accept liability for operation. The system is operated at the owner's own risk. The required visits to the system will be invoiced separately.

The installer/planner of the system is responsible for the operating instructions and for providing instruction in third-party products and/or the entire system! All Hoval hydraulic schematics and engineering guidelines serve as aids during planning. The planner/installer of the system is responsible for its correct functioning.

Heat sources

The heat source (with the exception of the temperature level of the heating system) significantly determines the efficiency, the operational safety and efficiency of a heat pump system. The most important factors are

- unrestricted availability during the utilisation period
- temperature level of the heat source during the utilisation period
- energy required for transporting the heat source
- chemical and physical safety of the heat source (working safety, maintenance work involved)

Proficient planning and undertaking of the heat source use are amongst the most important tasks for the planning and installer.

Heat sources that are predominantly used for heating living areas are natural and renewable heat sources such as:

- Fresh air
- Ground
- Ground water, waste water
- Surface water (lakes, rivers)

Waste heat utilisation with heat pumps involves using the heat pump for heat recovery in which the planning must take account not only of the usual criteria such as temperature level, type (waste water, extract air, exhaust gas), chemical and mechanical cleanliness, etc. but also the simultaneity of availability and heat use. A precise analysis is absolutely essential.

Fresh air

Fresh air is available everywhere. The following aspects must be considered when planning with fresh air as the heat source:

- Area of application of the heat pump
- Output fluctuations of the heat pump due to temperature fluctuations of the heat source
- Defrosting losses of the heat pump
- Sound emission
- Condensation formation
- In coastal regions or other areas with salty air, corrosion can decrease the lifetime of the evaporator

Heat pumps have clearly defined application limits, which means it is essential to consider the application limits when designing the system.

Ground

Setting up and operating geothermal probes and ground source collectors requires official approval. The heat capacity and thermal conductivity of the soil depend on its composition and water content. It is possible to use it in two different ways

- Vertically with geothermal probes
- Horizontally with ground collectors

Observe the following:

- The heat withdrawn must always be significantly less than can be replenished naturally
- In bivalent systems, the dimensions of the heat source system must be suitable with regard to the amount of heat withdrawn (90 kWh per metre of geothermal probe length)

Geothermal probes

The planning criteria are:

- The specific heat extraction rate which depends on the thermal conductivity (λ) of the underground; a specific cooling capacity of max. 47 W/m probe length can be assumed as guidance values
- The max. heat extraction per year should not exceed 90-100 kWh per metre of geothermal probe length

In addition, the following aspects need to be considered:

- The lowest possible total hydraulic resistance through optimisation of the number of geothermal probes, probe diameter and depth
- **A certified, specialist drilling company must be used for planning and undertaking the geothermal probe system**

Ground collectors

The energy that is used for compensating for the heat deficit or heat surplus comes almost exclusively from solar radiation and percolating water (rain, snow meltwater). A ground collector is, so to speak, as climate collector which is significantly influenced by weather events. The latent heat exploitation when there is a change of state in the water in the moist soil has a positive influence when it comes to calculating the balance. This means the evaporating temperature of the heat pump remains relatively constant over a long time. VDI 4640 must be taken into account during the design, as well as:

for the soil surface

- the climate zone and the aspect of the building
- the thermal conductivity of the soil and the effective number of operating hours

for the ground collector system

- the lowest possible total resistance
- by optimisation of the number of lines and line length
- If there is insufficient floorspace available, an alternative heat source must be sought

For further details see:
Heat source use/ground collectors.

Ground water

If the temperature of the ground water is below 8 °C in the seasonal profile, this must be taken into account in the planning.

Using ground water as a heat source requires official approval. Ground water is a very good heat source because of its high heat capacity and heat transfer properties.

Connection of ground water only via a separating heat exchanger (intermediate carrier circuit).

System-based clarifications are mandatory.

The most important criteria are:

- Hydro-geological report
- Water analysis
- Official approval/concession

In addition, the following aspects must be considered for the planning:

- The min. heat source temperature during the utilisation period
- The min. permitted evaporator outlet temperature of the selected heat pump
- The specifications of the authorities, such as the type of use, the design of the withdrawal and return well, etc.
- A qualified specialist company must be contacted for planning and installing the heat source system

In addition, the following aspects must be considered for the planning:

- VDI 4640
- Min. heat source temperature and flow rate during the utilisation period
- Official regulations such as type of use, configuration of the withdrawal and return well, etc.
- Possibility of infiltration through water from rivers or lakes
- The design must be based on reliable temperature data
- A certified, specialist drilling company must be used for planning and undertaking the system of ground water boreholes

The heat source must be free of chemical or mechanical contamination.

Surface water

If the temperature of the surface water is below 8 °C in the seasonal profile, this must be taken into account in the planning.

Planning a heat source system with sweet/river water, etc. as the heat source is a challenging task and demands great experience from the planner. Surface water use must be via an intermediate carrier circuit (separating heat exchanger). Under favourable conditions, for example close to the bank, it is possible to provide a filtering well (as with ground water) as well as an intermediate circuit (indirect use).

Use is not advised without reliable long-term information about the min./max. temperature of the heat source and chemical/mechanical safety.

A feasibility analysis and estimating the maintenance work involved are preconditions for implementation.

The dimensions of the heat exchanger for indirect use are as for ground water.

Using public surface water must be reported to the responsible water resources authority, as in the case of ground water use.

A qualified specialist company must be contacted for planning and installing the heat source system.

Heat sources

Geothermal probes

Schematic diagram heat sources/geothermal probes

- Geothermal probe system

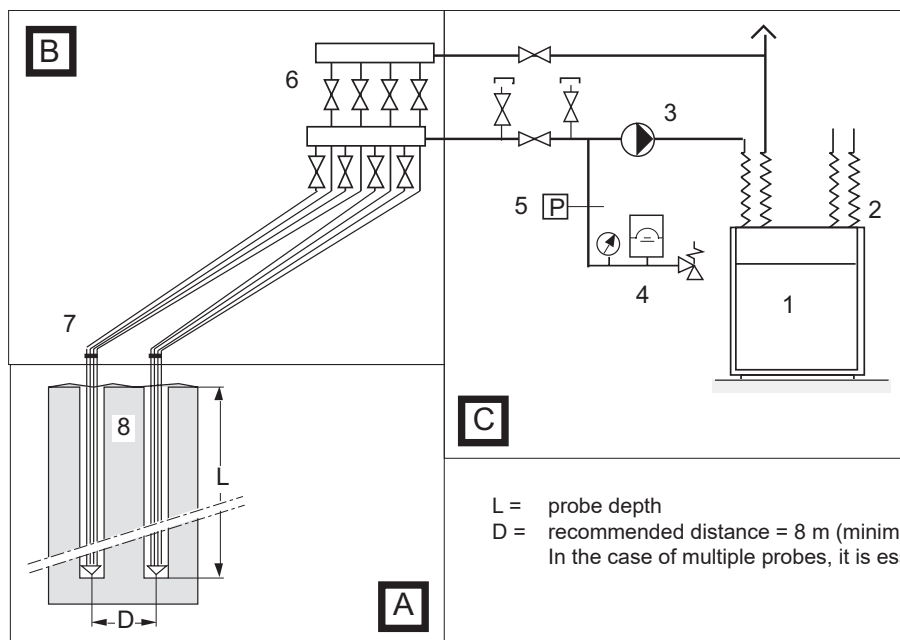

Field A) Geothermal probes

Drilling of geothermal probes including delivery and installation of the probe pipes. Backfilling with bentonite.

Field B) Connections

Manifolds/collectors, connection lines, making penetrations in walls and trenching.

Field C) Heat pump connection

Connecting pipes between manifold/collector and heat pumps incl. heat source feed pump, safety devices and fittings.

L = probe depth
 D = recommended distance = 8 m (minimum 5 m)
 In the case of multiple probes, it is essential to clarify the placement.

Legend	Field	Delivery	Installation
1 Heat pump	C	Hoval	Installer
2 Flexible connections	C	Hoval	Installer
3 Heat source feed pump (Cold water version)	C	Hoval	Installer
4 Diaphragm pressure expansion tank	C	Hoval	Installer
5 Pressure monitor	C	Hoval	Installer
6 Distributor/collector (PVC/C)	B	Installer	Installer
7 Connecting line (HDPE 32 or 40 mm Ø)	B	Drilling company or installer	on behalf of the installer
8 Geothermal probes	A	Certified drilling company	Drilling company on behalf of the client

If the heat source system is filled with water only, it must be specially dimensioned. It is mandatory to install a flow monitor and a frost protection thermostat.

Heat sources

Ground water

Preliminary information required

- Suitability regarding quantities and temperatures ($t \geq 6 \text{ }^\circ\text{C}$)
- Official approval
- Hydro-geological report
- Water analysis
- The effective minimum ground water temperature

Notices:

- The ground water temperature varies according to location.
- The design must be based on reliable temperature data

- The heat source system, (withdrawal and return well) must be installed by a specialist company

The heat source must be free of chemical or mechanical contamination.

Indirect utilisation with ground water

- The minimum ground water temperature during the utilisation period determines the tapping volume (required flow rate)
- In the case of river or sweet water, it is imperative to determine the precise temperature progression during the heating period
- The intermediate heat exchanger must be suitable for use with river or sweet water. Strainers and, if necessary, backwash filters are necessary to protect against contaminating particles such as sand. It must be possible to clean the heat exchangers.
- A filter must be installed upstream of the plate heat exchanger
- The hydraulic piping of the system must be carried out according to the selected hydraulic schematic.
- The intermediate circuit is filled with frost protection agent according to the engineering guidelines. The output of the heat pump can thus be read off for brine $5 \text{ }^\circ\text{C}$.
- The intermediate circuit pump must be planned in a cold-water design

Direct utilisation of ground water

State-of-the-art evaporator design (soldered plate heat exchangers) makes applications with a direct throughflow of ground water inadvisable

- These evaporators have very narrow flow channels and are extremely sensitive to even very fine dirt particles such as those abundant in ground water
- If individual channels become blocked, they can freeze, resulting in leakage towards the refrigeration circuit. This can cause irreparable damage to a machine
- Flow monitors and frost protection thermostats cannot detect obstructions, as the deviations are too slight to be registered
- Upstream fine filters can only solve the problem of obstructions to a certain extent, and need frequent cleaning
- The somewhat lower performance coefficient is more than compensated for by the high operational reliability
- In such cases, Hoval will not accept liability for damage to the evaporator

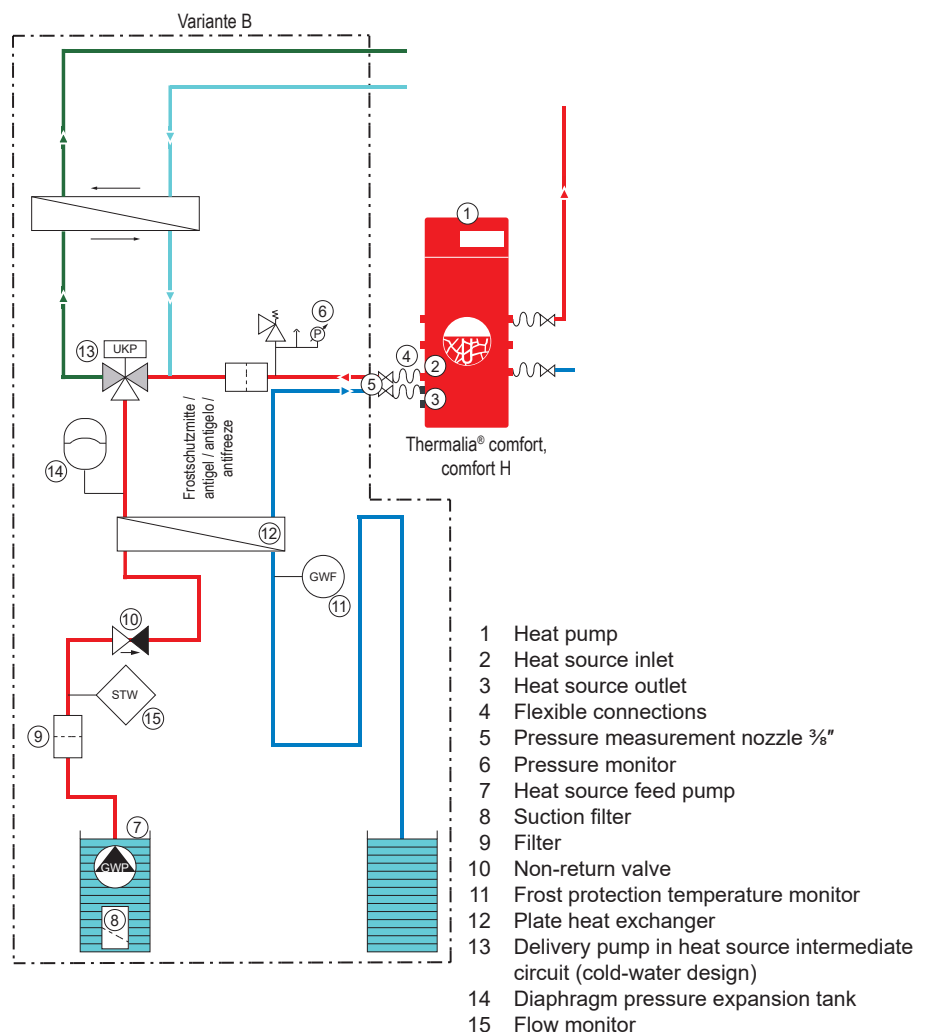

Other recommended components:

- Flow jacket (when in use)
- Securing/recovery rope
- Rope clamp
- Dry running protection
- Wall anchor
- Water quantity meter
- Vacuum breaker or pressure holding valve

Notice

In the case of systems without an intermediate heat exchanger, Hoval accepts no liability for damage caused by soiling or freezing of the evaporator!

Heating

Heat utilisation system (heat sink)

Heating

The heat pump is a compression cooling machine and behaves very dynamically.

This requires suitable flow rates through the heat exchangers of the heat pump on both the heat source and heat utilisation side. Since the heat exchangers of the heat pump have very low water contents, the constantly changing heat output demand of the system (predominant time of the heating period!) leads to excessive switching frequencies. However, short intervals mean insufficient time for stabilisation of the refrigeration circuit (loss of efficiency) on the one hand, and can lead to compressor failures on the other. In addition, there is the requirement of the electricity companies, which limit the switching frequency to 3 times per hour due to grid stability considerations.

Therefore, suitable measures must be taken or the system must be planned in such a way that the boundary conditions of the heat pump and the requirement of the electricity company can be met at all times.

The most important criteria for meeting the boundary conditions are:

- Correct flow rate through the heat pump during the entire time of use
- Sufficient storage capacity and a minimum water volume of the heat utilisation side (heating)

Underfloor heating systems without thermostatic valves can meet these requirements in most cases.

If the boundary conditions cannot be met, the heat pump must be hydraulically decoupled from the heat utilisation system (heating). A buffer storage tank is required for this. The buffer storage tank ensures that the boundary conditions of the heat pump can be met in any load condition of the system.

Water heating

Generous dimensioning of the calorifier in terms of heat exchanger and drinking water volume is recommended. The maximum heat output of the heat pump is decisive for setting the size of the heat exchanger.

- Recommended heat exchanger area
0.3-0.4 m² per kW max. heat output of the heat pump during the operating time of the system (air/water heat pumps at A20/W50)
- Min. drinking water volume = daily requirement
- In two-stage heat pumps, the output of the first stage can be used.

Example Heating

System example: Brine/water and water/water heat pumps without buffer storage tank

Application

Underfloor heating with heat storage capacity, low temperature heating system with heating group without thermostatic valves

Heat pump function

The heat pump works in dependence on the outdoor temperature (2-point regulator) with continuously controlled operating mode. The underfloor heating balances unfavourable output/load ratios.

The heat pump is put into operation when the temperature level in the return falls below a preset level. Switch-on and switch-off command via return sensor.

The switching difference is adjustable.

The additional re-switching delay allows a maximum of 3 starts per hour.

The switching function is controlled by a micro-processor, allows long runtimes and ensures a higher annual coefficient of performance for the heat pump.

Heating controller

The weather-controlled heating controller (2-point controller) guarantees a good heat supply to the heating system and works in a user-defined manner.

Ensure a minimum system water content.

If the heating circuits are equipped with thermostatic valves, a bypass with a relief valve must be installed.

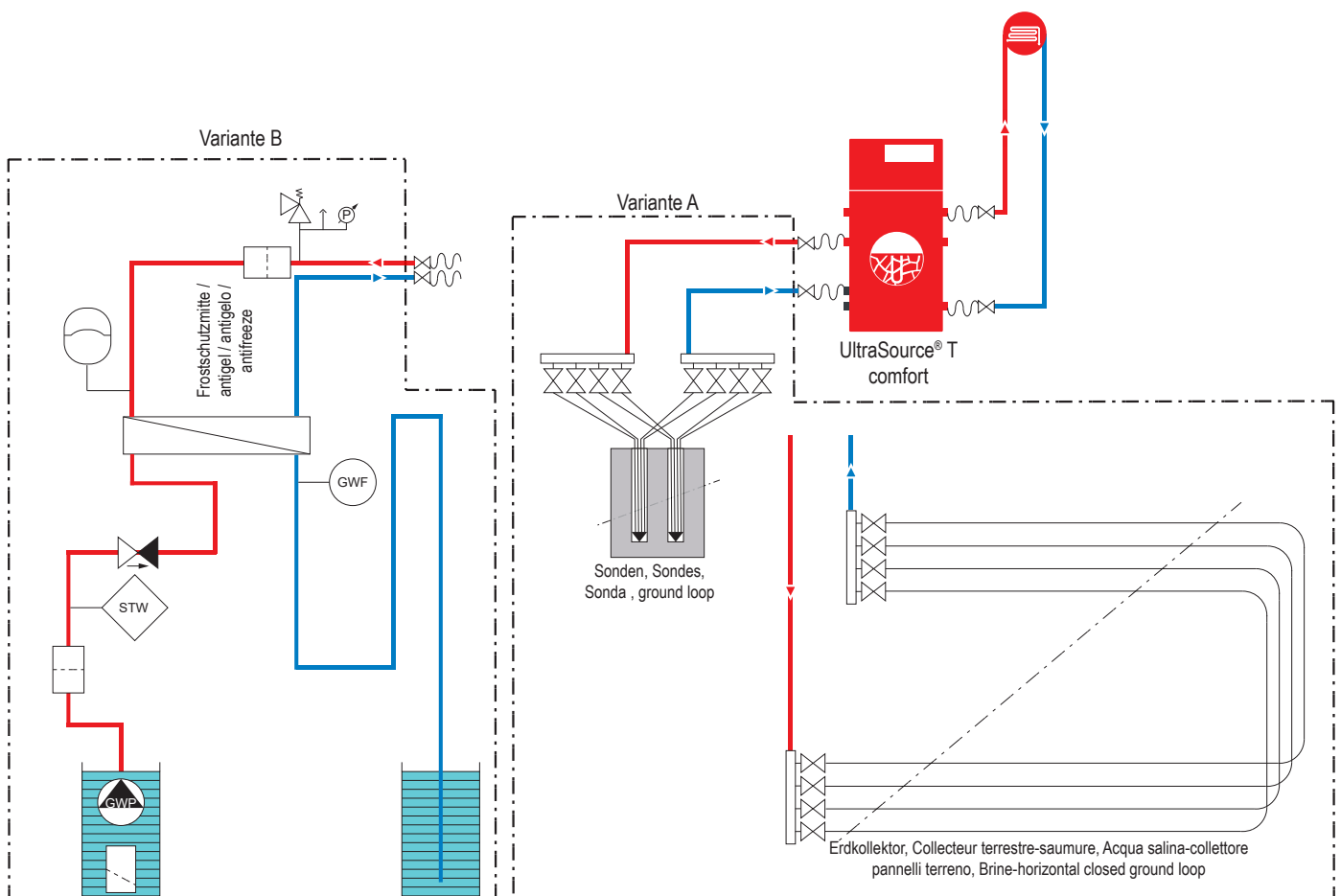

Notice

The example schematics merely show the basic principle and do not contain all information required for installation. The installation must be done according to local conditions, dimensioning and regulations.

Example Heating

System example: Brine/water and water/water heat pumps with buffer storage tank and calorifier

Application

Low temperature heating system with max. 2 heating groups, one buffer storage tank and one calorifier

Heat pump function

The heat pump works in dependence on the outdoor temperature (2-point regulator) with continuously controlled operating mode. The buffer storage tank balances unfavourable output/load ratios, allows energy-efficient and user-defined discharge and has a positive influence on the service life of the heat pump.

The heat pump is only put into operation when the temperature level in the buffer storage tank no longer meets heating system requirements and is taken out of operation when the additional output can no longer be absorbed by the buffer storage tank.

The switching difference is adjustable and allows long runtimes.

The additional re-switching delay allows a maximum of 3 start-ups per hour and guarantees a long service life. The switching functions are controlled by a microprocessor, ensuring long runtimes and a high annual Coefficient of Performance for the heat pump.

Heating controller

The weather-controlled heating controller (3-point controller) as a discharge control guarantees an optimum heat supply to the heating system and works in a user-defined manner for maximum convenience.

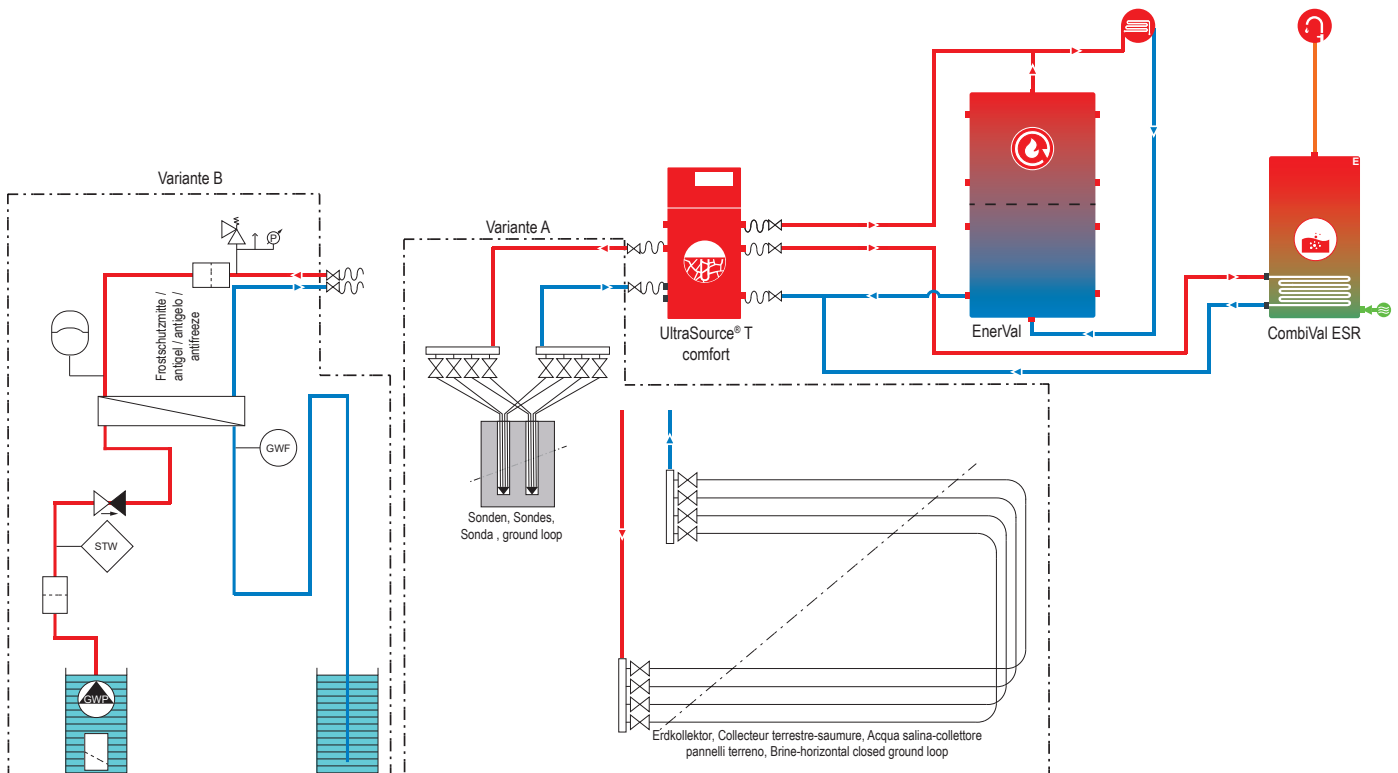

Notice

The example schematics merely show the basic principle and do not contain all information required for installation. The installation must be done according to local conditions, dimensioning and regulations.

1 Explanation

To use the geothermal heat, depth probes (preferably 2-circuit probes) are inserted into the ground to a max. depth of 200 m per bore hole. The collector pipes contain a mixture of water and frost protection agent which is circulated by means of a circulating pump. The energy is transferred to an intermediate heat exchanger, which is where the evaporation takes place.

A letter of approval is required from the authorities to lay a heat pump unit with depth probe.

2 Dimensioning of the deep borehole

The quick guide offers guide values for planning and is not intended as a substitute for geological evaluation.

In the case of special applications which do not increase the output of the heat pump (e.g. outdoor swimming pool), the heat source must be enlarged if the annual runtime is extended (greater annual extraction).

3 Laying/drilling depth

The boreholes are made according to calculation and the probes are inserted by the drilling company. If the subsoil actually hit differs from the projected geology, the depth of the borehole(s) must be adjusted to the new situation! The connection pipes are laid in trenches at a depth of approx. 1.2 m.

4 Laying/drilling spacing

Centre of deep borehole to centre of deep borehole min. 7 m (depending on the approval from the authorities, other distances can be stipulated). Larger distances between the boreholes reduce the additional allowance made for the total borehole metres.

The connection pipes are to be laid in a sand bed with a minimum distance of 50 cm.

5 Laying/drilling area

The surface must be undeveloped and even, and have only a minimal slope. The drilling points must be accessible with a drilling device (approx. 20 t in weight, approx. 3 m wide). The position of the depth probes and connection pipes is to be drawn on a plan, which remains on the heat pump.

6 Bringing in the depth probes

The drilling company makes the borehole, inserts and backfills the probe and performs a pressure test. Ensure that the probe is properly and sufficiently backfilled from bottom to top. It is recommended to use 2-circuit (duplex) probes. Water and electricity are needed to make the borehole. The drilling mud must be capable of being stored at the borehole (skip or container). Buildings should possibly be protected against splash water from the drilling. If several boreholes are required, ensure that the boreholes all have the same depth and that the connection pipes are all the same length in order to ensure equal rock pressure conditions. Otherwise, flow rate indicators have to be installed. It is recommended to lay warning tapes approx. 50 cm above the connection pipes. The brine circuit is to be filled with a water-frost protection agent mixture with a frost protection of $-15\text{ }^{\circ}\text{C}$ (when using the 33 % in vol. Hoval frost protection concentrate). Practical guide: Use water that has been preheated to $30\text{ }^{\circ}\text{C}$ when mixing so that a lasting mixture is ensured and a sound measurement of frost protection is possible.

7 Safety distances

Between the boreholes: min. 7 m.

To water pipes, ducts, buildings, walls and area borders: min. 3 m.

Depending on the approval from the authorities, other distances can be stipulated.

8 Connection pipe to heating house

It is recommended to join the collector circuits to a shaft (preferably Hoval geothermal heat shaft), so that only two pipes have to be fed to the heating house. The geothermal heat shaft must be rainwater-tight and it is essential that it is drained (gravel layer, drainage, etc.). The connection pipes are also to be laid in a sand bed.

Configuration of the connection pipe according to applicable standards of the country in question.

The following dimensions are recommended (material PE-HD PN 10):

UltraSource® T (8), Thermalia® comfort (8-10), comfort H (7,10): DA 40
UltraSource® T (13,17), Thermalia® comfort (13,17), twin H (13): DA 50
Thermalia® twin (20,26), twin H (19,22): DA 63
Thermalia® twin (36-42), dual (55), dual H (35,50), dual R (55): DA 75
Thermalia® dual (70,85), dual H (50-90), dual R (70,85): DA 90

The specified dimensions are sufficient for connection pipes with a length of approx. 25 m (one direction). For longer connection pipes, choose a larger pipe diameter.

9 Curing time

Standard cement-bentonite mixtures for the grouting of the depth probes have a curing time of 28 days. Within this time period, the depth probe cannot be operated yet. Ask the drilling company about this.

10 Commissioning

Commissioning of the heat pump is carried out exclusively by Hoval customer service. The heat pump must be electrically connected and the system filled, well flushed and vented. After commissioning, the customer receives a completion certificate.

1 Explanation

To use the ground water heat, pumping and injection wells are mounted. A submerged pump pumps the ground water through an intermediate heat exchanger. This intermediate circuit, which is filled with frost protection agent, transfers the energy to a heat exchanger in the heat pump, which is where evaporation takes place. A letter of approval is required from the authorities to mount a water/water heat pump unit.

2 Direct utilisation of ground water (without intermediate circuit)

The design of modern evaporators (brazed plate heat exchangers with very narrow plate spacing for high transfer rates) is such that applications with direct ground water through-flow are not allowed. These evaporators have very narrow flow channels and are extremely sensitive to even very fine dirt particles such as those abundant in ground water. If individual channels become blocked, they can freeze, resulting in leakage. This can cause irreparable damage to the heat pump. Flow monitors and temperature monitoring devices cannot be used, as the deviations are so slight that they are not registered. Upstream fine filters provide only a partial solution to the problem and need frequent cleaning.

Notice

In the case of systems without an intermediate heat exchanger (direct utilisation of ground water), Hoval accepts no liability for any damage caused by soiling or freezing of the evaporator!

3 Indirect utilisation of ground water (with intermediate circuit)

The somewhat lower performance coefficient is more than compensated for by the high operational reliability. Even with indirect use, ground water analysis is essential to allow selection of the appropriate intermediate heat exchanger and in order to identify problems caused by iron or manganese in combination with oxygen. Ideally, a separating heat exchanger in gasketed design should be used. Such heat exchangers can be dismantled for cleaning and have wider plate spacing. The hydraulic piping of the system must be carried out according to the selected hydraulic schematic. The intermediate circuit is filled with frost protection agent for frost protection of -15 °C (corresponds to 33 % in vol. Hoval frost protection concentrate). The output of the heat pump can thus be read off for brine 7 °C .

4 Ground water

A pump trial run of at least 3 days must be performed in order to ascertain the effectiveness and in order to “clean” the production well. The minimum permissible temperature of the returned ground water is 5 °C .

For the intermediate heat exchanger, the following limit values must be observed during the entire operating time of the heat pump (groundwater analyses are essential, the water quality can change constantly):

ph-value	7-9
Sulphates	< 100 mg/l
Chlorides	< 50 mg/l
Nitrates	< 100 mg/l
Phosphates	< 2 mg/l
Free chlorides	< 0.5 mg/l
Free carbonic acid	< 20 mg/l
Ammonia	< 2 mg/l
Iron	< 0.2 mg/l ¹⁾
Manganese	< 0.1 mg/l ¹⁾
Oxygen	< 2 mg/l ¹⁾
Electric conductivity	50-600 $\mu\text{S/cm}$

¹⁾ If the limit value for iron or manganese is exceeded, the presence of oxygen leads to silting up of the heat exchanger or formation of iron and manganese oxide deposits in the injection well.

5 Wells

Two bored wells are ideally mounted. However, where the geology permits this, the injection well can also be used as an absorbing well. Chiselled wells are to be avoided. The injection well should be at least 10 to 15 m away from the ground water flow (depending on the ground water situation, greater distances may be necessary).

6 Connection pipe

The supply and drainage pipes must be laid so that they are protected against frost at a minimum depth of 1.5 m. Ensure that there is a slight slope to the well.

From the production well, a feed pipe is to be laid for the electrical supply pipe of the pump. A backflushable fine filter with a maximum mesh size of 0.5 mm must be placed in the supply pipe, upstream of the heat pump.

A flow monitor is to be installed in the drainage pipe, upstream from the heat pump, to protect the heat pump (observe the installation instructions). After the flow monitor, a throttle valve is to be installed to adjust the flow rate. The connection pipes are also to be laid in a sand bed.

The following dimensions are recommended (material PE-HD PN 10):

UltraSource® T (8), Thermalia® comfort (8-10), comfort H (7,10): DA 40
 UltraSource® T (13,17), Thermalia® comfort (13,17), twin H (13): DA 50
 Thermalia® twin (20,26), twin H (19,22): DA 63
 Thermalia® twin (36-42), dual (55), dual H (35,50), dual R (55): DA 75
 Thermalia® dual (70,85), dual H (50-90), dual R (70,85): DA 90

The specified dimensions are sufficient for connection pipes with a length of approx. 25 m (one direction). For longer connection pipes, choose a larger pipe diameter.

7 Design of the well pump

$$m_w = \frac{(Q_k \times 3600)}{(c \times \Delta T)} \quad [\text{kg/h}]$$

m_w = mass flow [kg/h] (corresponds approx. to a water flow rate [l/h])

Q_k = refrigerating capacity of the heat pump = heat output – electrical output [kW]

c = specific thermal capacity [kJ/kg.K] ($c = 4.187\text{ kJ/kg.K}$)

ΔT = temperature difference [K] (cooling down of the ground water)

3600 = conversion factor (1 kWh = 3600 kJ)

Rule of thumb: 200 l/h per kW heat pump heat output with a temperature difference of 4 K. Underwater pumps with an integrated non-return flap must be used.

8 Commissioning

Commissioning of the heat pump is carried out exclusively by Hoval customer service. The heat pump must be electrically connected and the system filled, well flushed and vented. After commissioning, the customer receives a commissioning report.

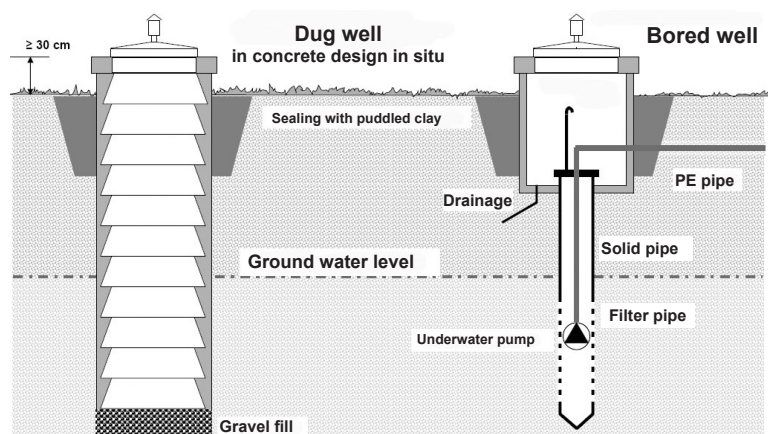

Active/passive cooling

- The low temperature can be output into the room using various systems.
- Structural conditions (underfloor heating) and requirements on the room air status (dehumidification, room air temperature) must be taken into account when selecting the system.
- It is a good idea to plan a separate cooling circuit for cooling. It can, for example, be combined with a cooling ceiling or a ventilation system.
- For lower comfort requirements where a cooling effect suffices, heating via underfloor heating or partial cooling via fan convectors is also possible.
- Special thermostatic valves are required that are suitable for heating and cooling operations. Standard thermostatic valves for heating systems close at low room temperatures.

■ Examples

Active cooling

Cooling via panel heating

- In panel cooling, the surfaces enclosing the room (ceilings, floors or walls) are cooled by the following systems:
 - Underfloor heating, wall heating
 - Cooling ceilings
 - Concrete core temperature control
- In all panel cooling systems, the temperature at the surfaces is not allowed to fall below the dewpoint temperature so that condensation will not form.
- The fixed value of 18 °C is not allowed to be reduced by the user.
- Dehumidification of the room air is not possible with panel cooling systems, and must be performed using additional systems if required.
- If the room air is not dehumidified, the relative humidity will increase as the room temperature falls – which can lead to a reduction in comfort.
- A plate heat exchanger is installed in the brine circuit (passive cooling).
- The minimum cooling temperature (dewpoint temperature) is regulated by a 3-way motorised mixer.

- A dewpoint monitor is required so as to avoid condensation formation (dropping below the dewpoint) on the cooling surfaces.

Cooling by fan convectors

- Recommended use only with active cooling
- The heat pump must be equipped with a flow monitor.
- Fan convectors can cool and dehumidify the room air. This increases the comfort level
- In fan convectors, cold water flows in the cooling circuit at a temperature below the dewpoint. The resulting condensation must be drained away.
- The connection pipes to the fan convector must be insulated to prevent vapour diffusion and avoid any condensation forming on them.

Pipe systems

- Materials resistant to corrosion must be used, such as plastic, chromium steel or a steel that has been treated to resist corrosion.
- Galvanised pipes or fittings are not allowed to be used.
- In the building, the network of pipes including storage tanks and fittings must be insulated to prevent vapour diffusion and avoid any condensation forming.

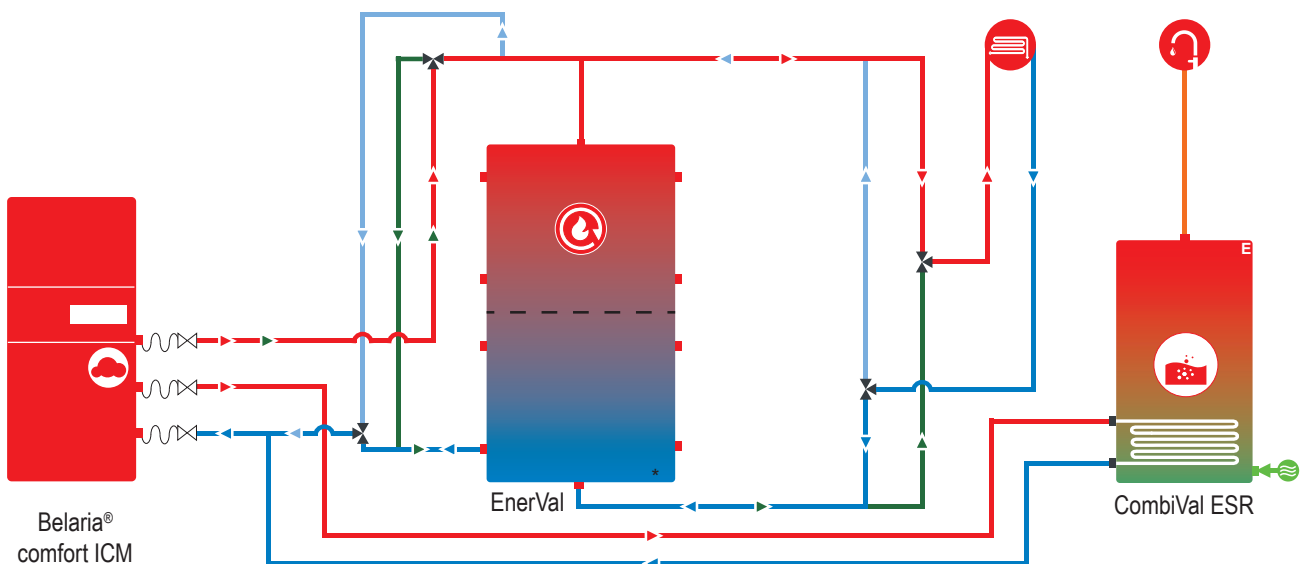

Notice

The example schematics merely show the basic principle and do not contain all information required for installation. The installation must be done according to local conditions, dimensioning and regulations.

Example Cooling

Active cooling

The cooling energy is produced actively with the heat pump for the purpose of cooling. To achieve this, process reversal is carried out in cooling operation. In this case, the heat utilisation side (condenser) becomes the heat absorption side (evaporator). In contrast to passive cooling, the compressor energy must be produced additionally. Cooling/heating operation cannot take place simultaneously. To ensure that the heat pump does not receive too many on/off switching and switchover commands to water heating, we recommend the use of a cooling buffer tank in every case. Depending on the system concept, the buffer storage tank can also be used as a cooling storage tank.

General notes on cooling

- Cooling operation must always be monitored. If the room temperature is cooled in an unlimited manner, condensation will form. This, in turn, can damage components. We recommend monitoring the flow temperature in combination with the moisture (dewpoint limit thermostat).
- It is of advantage to plan a separate cooling circuit for cooling. It can, for example, be combined with a cooling ceiling or a ventilation system. For lower comfort requirements where a cooling effect suffices, heating via underfloor heating or partial cooling via fan convectors is also possible.
- The water flow must be guaranteed, otherwise no cooling can take place. In case of cooling via the heating surfaces, individual thermostatic controls must be used, which can be switched to cooling mode. Otherwise the valves are closed in the summer and cooling cannot take place.

Planning

- Hydraulic integration is ideally via a cooling buffer.
- A mixer is required for adjustment of the cooling load of the rooms to the outdoor temperature.
- To prevent the formation of condensation, the buffer and all brine and cold water pipes must be rendered vapour-impermeable and thermally insulated in accordance with recognised engineering practices.
- Cooling mode is switched on or off manually.
- To protect against frost damage in the condenser, it is mandatory to install a flow monitor in the pump circuit (see schematic).

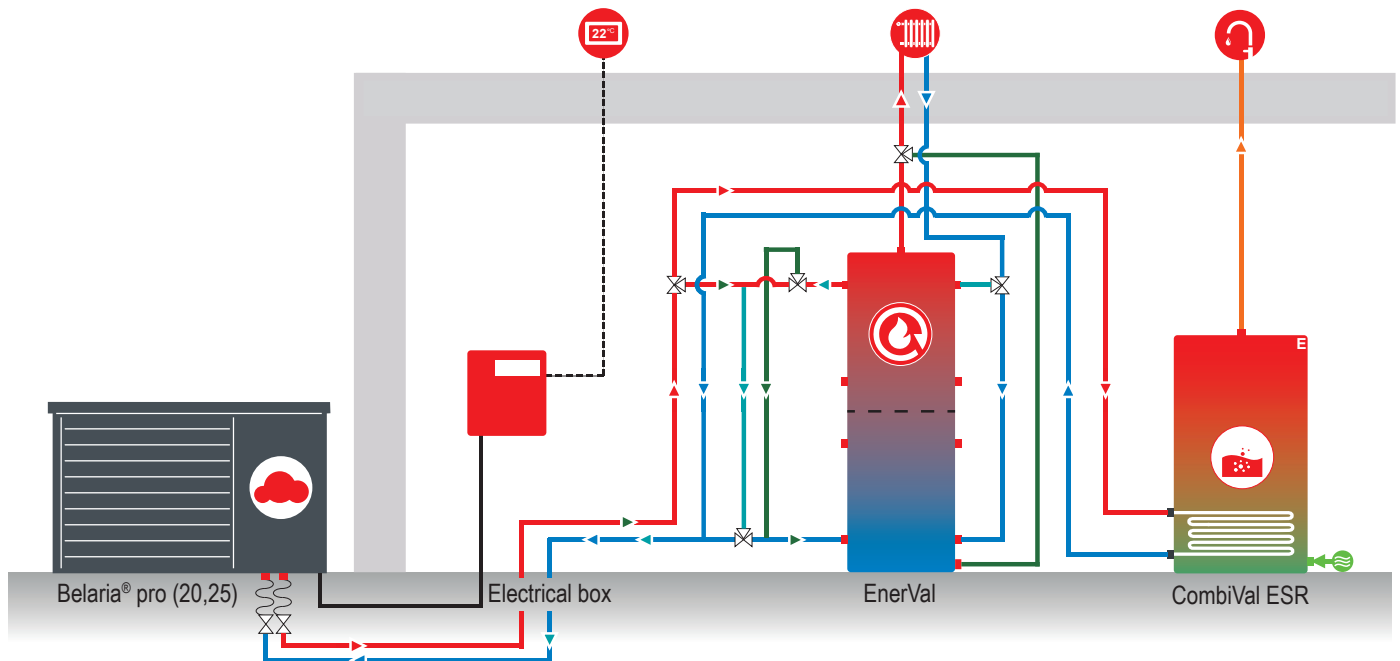

Notice

The example schematics merely show the basic principle and do not contain all information required for installation. The installation must be done according to local conditions, dimensioning and regulations.

Example Cooling

Passive cooling via geothermal probes

Increasingly, at our latitudes, cooling of living areas is offered with the geothermal probe via the panel heating (underfloor or wall heating). The following instructions should be followed for careful planning and also to ensure that the user is fully aware of the limitations of this equipment technology, and operates the system correctly.

Planning

- The dewpoint in the floor or wall must not be undershot at any time.
- This is achieved by a fixed value regulation of the flow temperature.
- The fixed value must be set high enough to ensure that the dewpoint is not undershot.
- The flow temperature setpoint is limited to min. 18 °C.
- The cooling must be switched on and off manually.

The following must be observed for systems with cooling by floor or wall surfaces:

- The cold remains largely on the floor.
- This temperature distribution can be perceived as uncomfortable: the occupant has cold feet and a warm head.
- The temperature difference between the cooling surface and the air is very small.
- No guaranteed cooling capacity can be specified.
- Like panel heating, panel cooling also responds slowly.
- No condensate is discharged; thus the relative humidity in the room increases.
- The lower room temperature combined with the high relative humidity scarcely improves comfort. A humid climate is created.
- The minimum limit of 18 °C is not allowed to be reduced by the user.

Note the following in comparison with a small air conditioner:

- The energy savings compared to the air conditioner are small.
- An air conditioner dehumidifies the air; a humid climate is not created.
- An air conditioner delivers a cooling effect rapidly after being switched on.
- The costs of an air conditioner are comparatively low.

Comparison with other cooling systems:

Surface cooling systems are also used in some cases for cooling office buildings. However, these are usually ceiling cooling systems in conjunction with ventilation. So it is a combination of cooling by radiation (ceiling) and bringing in cool air (with dehumidification). This convenient system technology is usually too complicated and expensive for residential use. Ventilation convectors with condensate drip tray represent another option for air conditioning. Cooled and dehumidified air is introduced at certain places via the convectors (there should be no draughts). In this case, a reversible heat pump that can provide active cooling can also be used.

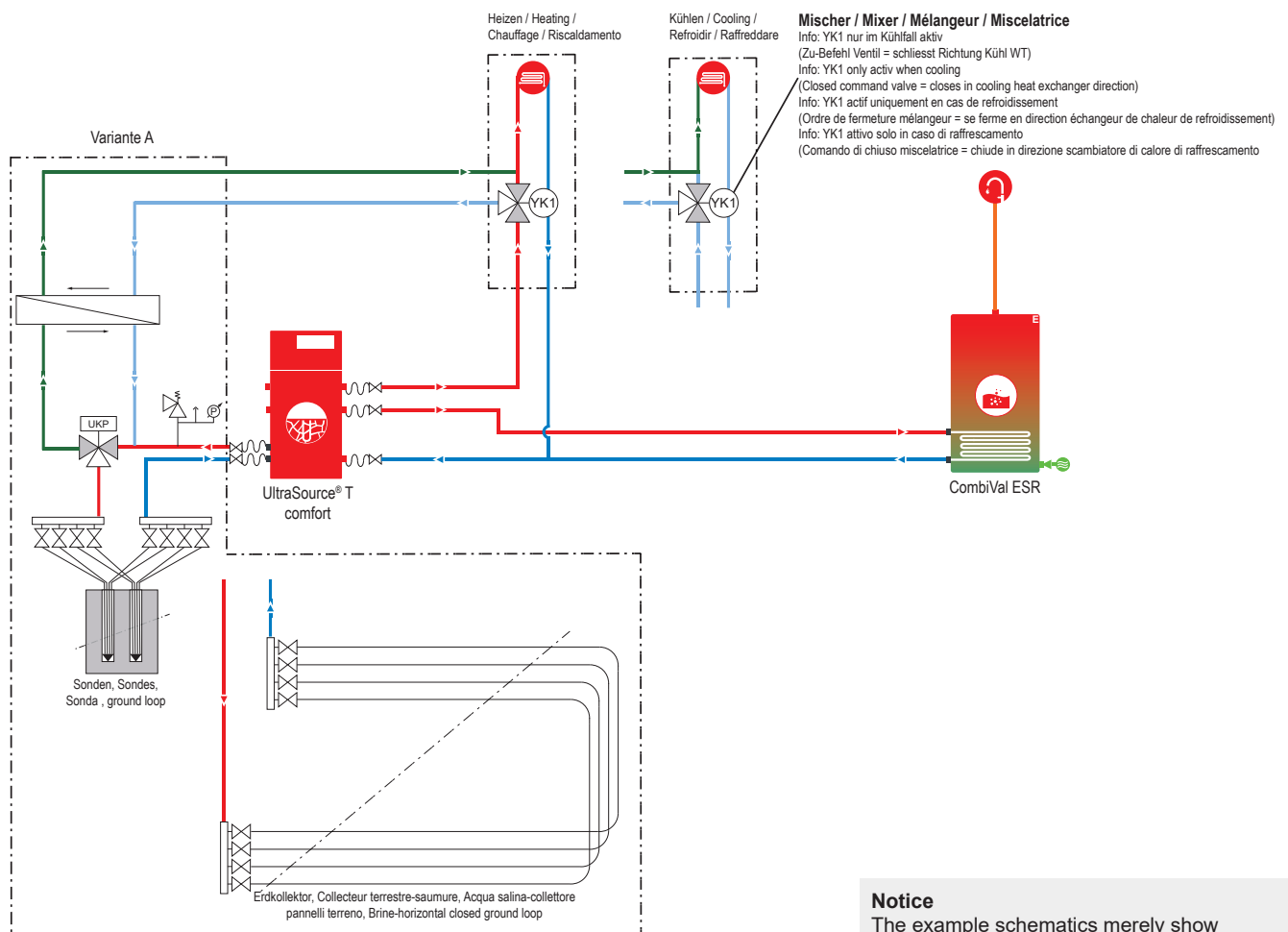

Notice

The example schematics merely show the basic principle and do not contain all information required for installation. The installation must be done according to local conditions, dimensioning and regulations.

Smart Grid (PV function)

Load management with heat pumps

Heat pumps are currently the most efficient method of storing electricity from volatile generation (electricity from renewable sources such as: wind power, photovoltaic systems or even from combined heat and power).

Smart Grid in this context refers to an intelligent power system.

In contrast to earlier electricity connections that only operate in one direction, the Smart Grid features many distributed electricity generation and consumption systems.

It is obvious that it makes most sense to consume the electricity close to where it is generated. This reduces the grid system load and the public grid system predominantly functions as a balancing mechanism.

The following conditions must be met by the system for efficient and convenient operation:

- Smart meter electricity tariff or the building's own PV system/small wind turbine with Smart Grid-capable inverter or PV load manager (own electricity consumption)
- Heat pump
- TopTronic® E
- Sufficiently large buffer storage tank
- Mixer circuit
- Possibly additional electrical heating

The heat pump is switched on and off or controlled depending on atmospheric conditions. Moreover, it is switched on when a particular green electricity surplus is reached and charges the buffer storage tank and any calorifiers to a higher temperature.

At times when no green electricity is available any longer, the heating is supplied from the charged buffer storage tank. The heat pump needs to be operated less frequently during periods when no or only a little internal current is being generated.

SG Ready standard:

This defines the following 4 functions depending on the PV surplus:

- Normal operation (no influence)
- Heat pump inhibit
- Preferential operation (increased operation)
- Forced acceptance (max. operation)

This is implemented using 2 digital inputs on the TopTronic® E. A 4-core signal cable from the inverter/PV load manager or from the Smart Meter to the heat pump is required for this. The information must be provided potential-free.

0-10 V control:

An on-site energy manager provides a 0-10 V signal which is dependent on the PV surplus. Preferential operation (increased operation) and forced acceptance (max. operation) are activated by adjustable thresholds in the TopTronic® E depending on the available electrical output (PV surplus).

Hoval EnergyManager PV smart:

In addition to the remote monitoring function, the online connection (HovalConnect) of the heat pump system also has the Hoval EnergyManager PV smart integrated in it. The Hoval EnergyManager PV smart operates with the solar radiation indicated in the weather forecast, and acts either on the preferential operation (increased operation) or forced acceptance (max. operation).

Belaria® air/water heat pumps

			UltraSource® B comfort C		Belaria® pro comfort		Daikin Altherma 3 H HT W		Belaria® pro			Belaria® comfort ICM		Belaria® twin I, twin IR							
Heat generator type			(8)	(11)	(17)	(8)	(13)	(15)	(14)	(18)	(20)	(25)	(40)	(50)	(8)	(13)	(20)	(25)	(30)		
Material	Calorifier	Heating																			
	type	surface [m²]																			
Enamel	CombiVal (= CV)	ER	200	0.95																	
			300	1.45																	
			400	1.80																	
			500	1.90																	
			800	3.70																	
	ESR	200	1.80																		
		300	2.60																		
		400	3.80																		
		500	5.90																		
		800	7.00																		
	ESSR	1000	9.15																		
		300	0.80																		
		400	1.00																		
		500	1.30																		
		500	4.30																		
	ESRR	800	5.20																		
		1000	6.10																		
CombiVal (= CV)		CR	200	1.28																	
			300	1.28																	
			500	1.70																	
	800		2.63																		
	1000		2.63																		
CSR	300	2.56																			
	400	3.40																			
	500	5.26																			
	800	6.30																			
	1000	10.00																			
	1250	10.00																			
	1500	11.30																			
2000	12.70																				

The allocation of the calorifiers to the heat pumps is based on the heating surface of the storage tank coil, heat output of the heat pump for domestic hot water charging, maximum duration of domestic hot water charging and other parameters. For this reason, this allocation table only contains standard values.

Notice

For higher comfort requirements or a higher hot water requirement, we recommend the storage tank series with larger heating coils: series ESR and ESSR (or CSR).

Notice

The suggested combinations of heat pump with calorifier are a recommendation according to the suitable coil size and duration of domestic hot water charging (120 minutes). It is possible to deviate from the recommended combinations depending on how the customer uses it.

Thermalia® brine/water heat pumps

			UltraSource® T comfort			Thermalia® comfort, comfort H					Thermalia® twin, twin H				Thermalia® dual, dual H, dual R														
Heat generator type			(8)	(13)	(17)	(8)	(10)	(13)	(17)	H (7)	H (10)	(20)	(26)	(36)	(42)	H (13)	H (19)	H (22)	(55)	(70)	(85)	(110)	(140)	H (35)	H (50)	H (70)	H (90)		
Material	Calorifier type	Heating surface [m ²]																											
Enamel	CombiVal (= CV)	ER	200	0.95																									
			300	1.45																									
			400	1.80																									
			500	1.90																									
			800	3.70																									
	ESR	ESR	200	1.80																									
			300	2.60																									
			400	3.80																									
			500	5.90																									
			1000	9.15																									
	ESSR	ESSR	200	1.80																									
			300	2.60																									
			400	3.80																									
			500	5.90																									
			1000	9.15																									
MultiVal (= MV)	ERR	300	0.80																										
		400	1.00																										
		500	1.30																										
		500	4.30																										
		800	5.20																										
Stainless steel	CombiVal (= CV)	CR	200	1.28																									
			300	1.28																									
			500	1.70																									
			800	2.63																									
			1000	2.63																									
	CSR	CSR	300	2.56																									
			400	3.40																									
			500	5.26																									
			800	6.30																									
			1000	10.00																									
			1250	10.00																									
			1500	11.30																									
			2000	12.70																									

The allocation of the calorifiers to the heat pumps is based on the heating surface of the storage tank coil, heat output of the heat pump for domestic hot water charging, maximum duration of domestic hot water charging and other parameters. For this reason, this allocation table only contains standard values.

Notice
For higher comfort requirements or a higher hot water requirement, we recommend the storage tank series with larger heating coils: series ESR and ESSR (or CSR).

Notice
The suggested combinations of heat pump with calorifier are a recommendation according to the suitable coil size and duration of domestic hot water charging (120 minutes). It is possible to deviate from the recommended combinations depending on how the customer uses it.

Hoval quality.
You can count on us.

Hoval is one of the leading international companies for heating and indoor climate solutions. Drawing on more than 80 years of experience and benefiting from a close-knit team culture, the Hoval Group delivers exciting solutions and develops technically superior products. This leadership role requires a sense of responsibility for energy and the environment, which is expressed in an intelligent combination of different heating technologies and customised indoor climate solutions.

Hoval also provides personal consultations and comprehensive customer service. With around 2500 employees in 15 companies around the world, Hoval sees itself not as a conglomerate, but as a large family that thinks and acts globally.

Hoval heating and indoor climate solutions are currently exported to more than 50 countries.

Responsibility for energy and environment

Your Hoval partner

Liechtenstein

Hoval Aktiengesellschaft
9490 Vaduz
+423 399 24 00
hoval.com

United Kingdom

Hoval Ltd.
Newark Notts. NG 24 1JN
+44 1636 672 711
hoval.co.uk