

Hoval energy recovery

Plate heat exchangers

Design handbook

For energy recovery in ventilation systems
and in process engineering



Plate heat exchangers

Tight fold connections for good stability and leak-tightness



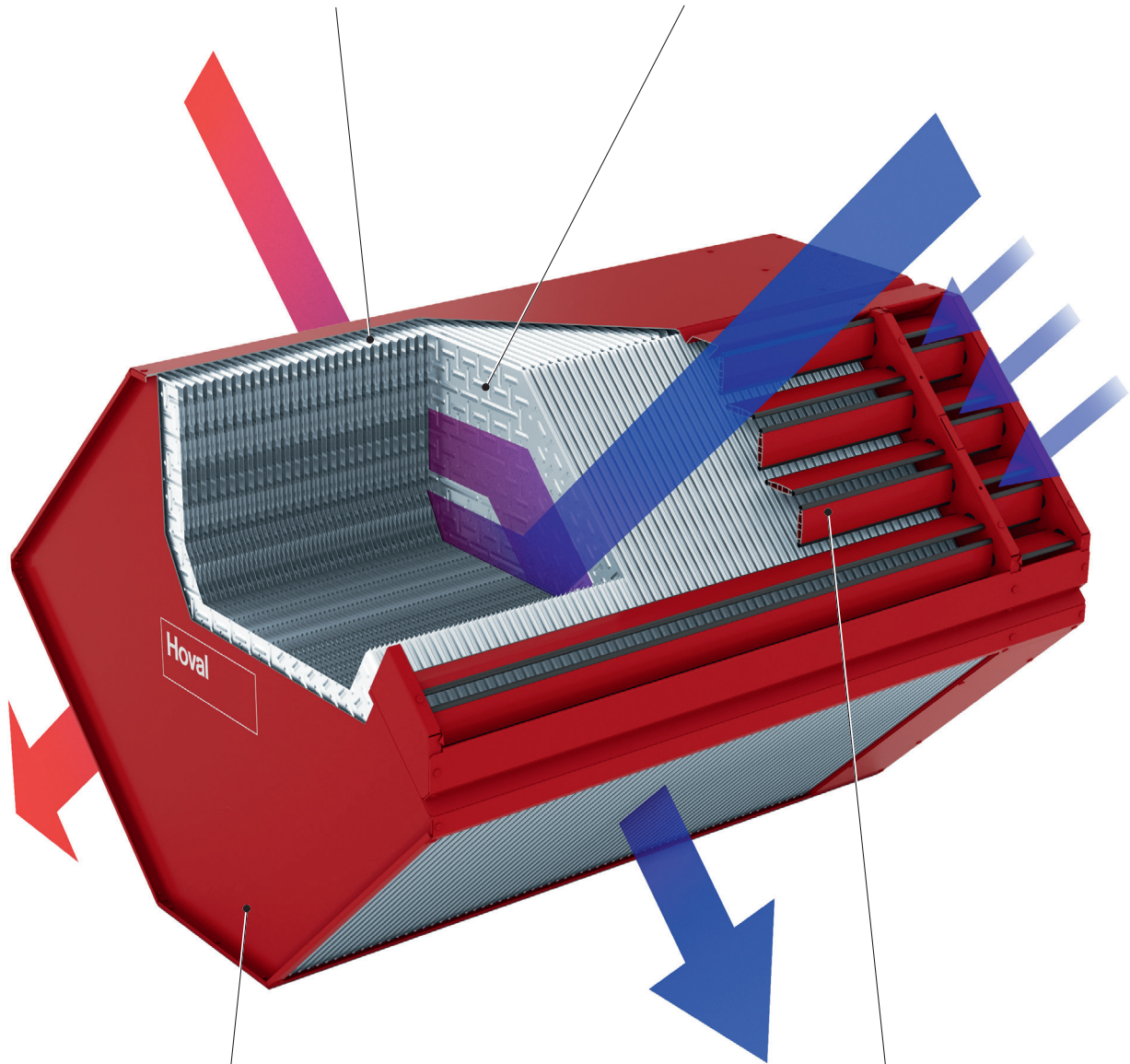



Profile optimised for highest air flow rate with a low pressure drop

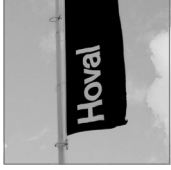

Hoval

Side walls either flat or with double folded edges

Complete package with bypass and control dampers from a single source

	Hoval energy recovery Economical. Reliable. Competent.	3
	At a glance Model range, type codes and availability	5
	Gotthard – design G Plate heat exchangers for air flow rates from 200 to 24000 m ³ /h	11
	Krivan – design K Plate heat exchangers for air flow rates from 200 to 100000 m ³ /h	25
	Design S Plate heat exchangers for air flow rates from 200 to 100000 m ³ /h	33
	Options	41
	System design	49

A

B

C

D

E

F

G



Hoval energy recovery

Economical. Reliable. Competent.

A





Economical. Reliable. Competent.

Hoval develops and produces components for heat, cold and moisture recovery for today and tomorrow. The systems are used in ventilation systems and in process technology. They use energy several times and thus achieve considerable savings.

Hoval offers a wide range of regenerative and recuperative systems for energy recovery:

- Rotary heat exchangers transfer energy through a rotating storage mass, which is alternately heated by one air stream and cooled by the other. They can transfer both temperature and moisture between air streams.
- Plate heat exchangers transfer energy through thin separating plates. The warm and cold air streams pass each other in crossflow. Energy is transferred between the air streams purely by heat conduction as a result of the temperature difference.

Economical

This investment in Hoval energy recovery systems pays off in several ways:

- high thermal efficiency with low pressure drop at the same time
- low installation costs
- low energy consumption
- minimum maintenance requirements

Reliable

Hoval systems for energy recovery are inspected time and time again by independent test institutes (for example at the building technology testing laboratory of the University of Lucerne). All technical data are based on these measurements. This means that they are reliable data for planners, installers and operators.



Competent

Hoval is one of the world's leading suppliers of plate heat exchangers and rotary heat exchangers with decades of industry experience. We support you with our expert know-how. You can rely on detailed technical advice from our engineers as well as on the competent deployment of our service technicians.



At a glance

Model range, type codes and availability

1 Model range	6
2 Type codes and availability	8



1 Model range

Hoval plate heat exchangers are important elements for saving energy in air handling units, in ductwork systems and in process engineering. A wide range of models is available for optimum adaptation to the application in question.

1.1 Designs

The technical demands on the exchanger package depend on the air flow rate and the application. The following designs are available:

Design	Air flow rate	Principle
G (Gotthard)	200 ... 100000 m³/h	Counter-cross flow
K (Krivan)	200 ... 100000 m³/h	Crossflow
S	200 ... 100000 m³/h	Crossflow

Table B1: Designs

1.2 Series

Series	Description
V	Standard Plates made of metal, casing made of metal sections and magnesium-zinc sheet, silicone-free
G	Corrosion-protected Materials as for series V, but the exchanger is coated and therefore better protected against corrosion.

Table B2: Series

1.3 Construction types

Construction type	Description
-	Standard Standard plate heat exchangers are single exchangers with double folded edges.
C	Combi block Exchanger in design G composed of 2 or 3 single exchangers and 2 air guides each, with double folded edges
F	Flat side walls Exchangers in design G are optionally available with side walls that do not have folded edges.

Construction type	Description
Z	Twin exchangers Twin exchangers are 2 single exchangers supplied separately, which are installed in the air-conditioning unit as a twin. Design Z is available as an exchanger package without bypass, with bypass or with bypass and control dampers. If dampers are ordered, they are only mounted on one of the two exchangers.

Table B3: Construction types

1.4 Exchanger sizes

Hoval plate heat exchangers are available with edge lengths from approx. 500 mm to 2400 mm in finely spaced steps. Some sizes are composed of several packages.



Construction	Size	Design		
		G	K	S
	055	●	–	–
	065	●	–	–
	075	●	–	–
	085	●	–	–
	110	●	–	–
	130	●	–	–
	150	●	–	–
	170	●	–	–
	195	●	–	–
	225	●	–	–
	255	●	–	–
	050	–	–	●
	060	–	–	●
	070	–	–	●
	085	–	●	●
	100	–	●	●
	120	–	–	●
	140	–	●	●
	170	–	●	●
	200	–	●	●
	240	–	–	●

Table B4: Exchanger sizes

1.5 Exchanger width

The width of the plate heat exchangers can be selected in steps of 1 mm:

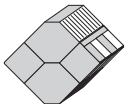
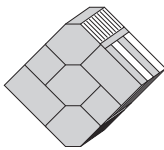
- Counter-flow exchanger: 200...4800 mm
- Crossflow exchanger: 200...4100 mm

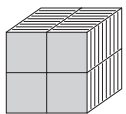
In order to simplify transport and installation, very wide exchangers are delivered in several parts. This applies for the following exchanger sizes:

Construction	Width	Design
	1201 ... 2400 mm	G-055 ... G-255
	2401 ... 3600 mm	G-055 ... G-255
	3601 ... 4800 mm	G-055 ... G-255
	1401 ... 2800 mm	S-050 ... S-060
	2051 ... 4100 mm	K-085 ... K-200 S-070 ... S-240
	2801 ... 4100 mm	S-050 ... S-060

Table B5: Exchangers with split width

1.6 Options

Optional components are precisely matched to the respective Hoval plate heat exchanger and round it off to form a complete package from a single source, for example:

- Bypass for performance control with control dampers
- Recirculation bypass with recirculation damper

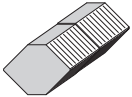
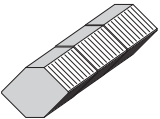
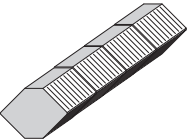
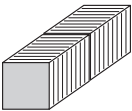
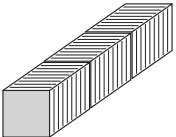

Fig. B1: Bypass for performance control



Fig. B2: Recirculation bypass control

2 Type codes and availability

Availability

S V - 200 / AL / 2100 / BSK 140 , 4P , L , H , Q1 , G2 , B4 , M , C001

Design		
G	Design G (Gotthard)
K	Design K (Krivan)
S	Design S
Series		
•	•	V Standard
•	•	G Corrosion-protected
Construction type		
•	•	- Standard
•		C Combi block
•		F Flat side walls (without bypass and dampers, up to size 085)
	•	Z Twin exchangers
Size		
•	•	Code for the size of the exchanger plates (050 to 255)
Efficiency / plate spacing		
•	•	Code for temperature efficiency
Exchanger width (outside width, any required size in steps of 1 mm)		
•		G-055 to G-170: 0200 mm – 4800 mm (with bypass: min. 500 mm)
		G-195 to G-255: 0500 mm – 4800 mm
	•	0200 mm – 4100 mm
Bypass and dampers		
•	•	BS-..... Side bypass
•	•	BSK..... Side bypass with dampers, plastic gear wheels
•	•	BSM..... Side bypass with dampers, metal gear wheels
•		XS-..... Side bypass on the opposite side
•		XSK..... Side bypass with dampers on the opposite side, plastic gear wheels
•	•	BM Middle bypass
•	•	BMK..... Middle bypass with dampers, plastic gear wheels
•	•	BMM Middle bypass with dampers, metal gear wheels
•	•	USK Side recirculation bypass with dampers, plastic gear wheels
•	•	USM..... Side recirculation bypass with dampers, metal gear wheels
•		ZSK..... Side recirculation bypass with dampers on the opposite side, plastic gear wheels
	•	YSK..... Side recirculation bypass with dampers on the opposite side, plastic gear wheels
	•	YSM..... Side recirculation bypass with dampers on the opposite side, metal gear wheels
•	•	UMK..... Middle recirculation bypass with dampers, plastic gear wheels
•	•	UMM Middle recirculation bypass with dampers, metal gear wheels

Availability

S V - 200 / AL / 2100 / BSK 140 , 4P, L, H, Q1, G2, B4, M, C001

G	K	S	
			Bypass width (inside width, any required size in steps of 1 mm)
•			7 % – 30 % of the exchanger width (max. 999 mm)
	•	•	050 mm – 999 mm
			Leakage test
•	•		4PLeakage test on 4 sides
			Horizontal installation
•			LHorizontal installation (with middle bypass: max. width 2000 mm)
	•	•	LHorizontal installation
			Adapter for actuator
•	•	•	HAdapter for actuator
			Packaging
	•	•	Q1Stronger packaging
			Partitioned delivery
•	•	•	G2Partitioned delivery
			Block supplied loose
•			B5Combi block, supplied loose
	•	•	B4Block of 4, supplied loose
			Optimum order quantity
•			MOptimum order quantity (only for G-055 to G-085 up to max. 1200 mm width)
			Customer code
•	•	•	C001Code for customer-specific attributes

Table B6: Type codes and availability



Gotthard – design G

Plate heat exchangers for air flow rates from 200...100 000 m³/h

1 Use12
2 Construction.12
3 Specification text.14
4 Technical data15

1 Use

Hoval plate heat exchangers of design G (Gotthard) are energy recovery units for installation in ventilation and air-conditioning units. They are available in different sizes, suitable for air flow rates from approx. 200 to 100000 m³/h.

The suitability of the heat exchangers for use both in general ventilation technology and in hospitals is certified by independent test institutes.

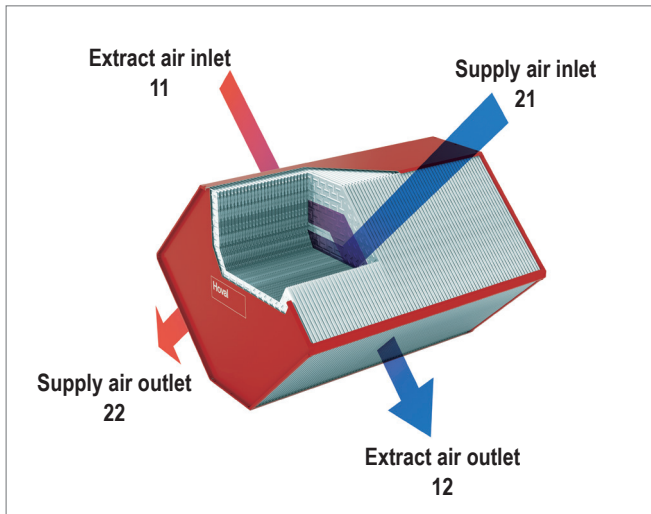

Fig. C1: Air flow through Gotthard plate heat exchanger

Definition of temperature efficiency
$\eta_t = \frac{t_{22} - t_{21}}{t_{11} - t_{21}}$

2 Construction

Gotthard plate heat exchangers consist of the exchanger package and the casing. Sizes 110 – 255 are combi blocks composed of 2 or 3 single exchangers and 2 air guides each.

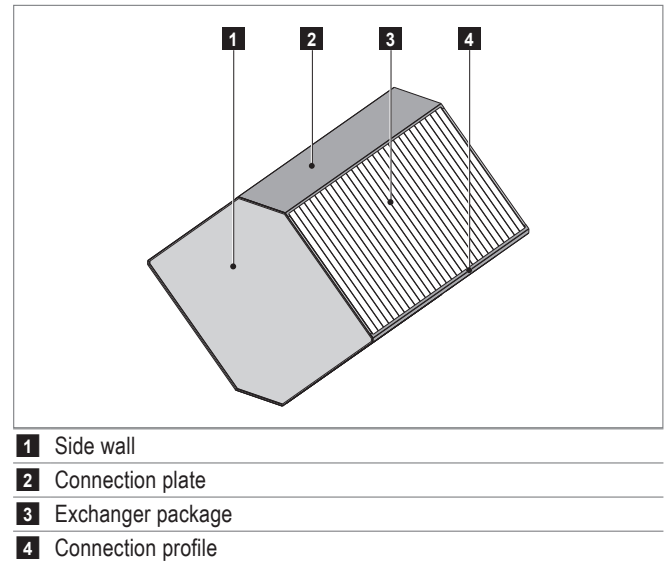

Fig. C2: Structure of Gotthard plate heat exchanger

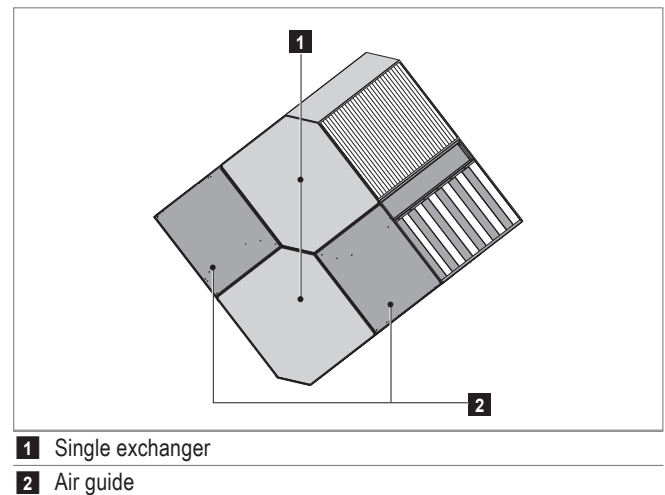
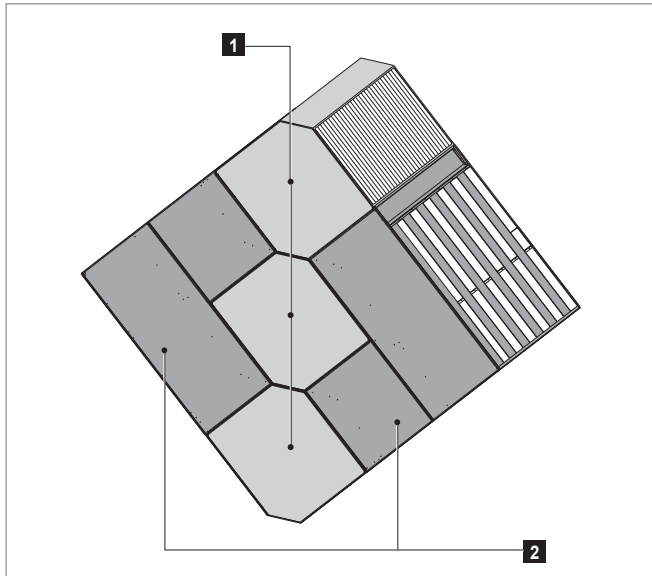

Fig. C3: Sizes 110 – 170 are combi blocks composed of 2 single exchangers and 2 air guides



1 Single exchanger
2 Air guide

Fig. C4: Sizes 195 – 255 are combi blocks composed of 3 single exchangers and 2 air guides

2.1 Exchanger package

The exchanger package consists of specially formed aluminium plates. Their profile is an optimum design resulting from detailed tests for temperature efficiency, pressure drop and rigidity. There are different plate sizes, which are formed with different profile depths, i.e. for different plate spacings and thus different efficiency values. The connection of the plates is made by a double fold. This gives a several-fold material thickness at air entry and exit, which lends the exchanger package a particularly high stability and leak-tightness.



Fig. C5: Double fold connections give the exchanger package several-fold material thickness for the leading and trailing edges

2.2 Casing

The exchanger package is fitted into a casing of connection profiles and side walls.

- The corners of the exchanger package are sealed into the magnesium-zinc sheet steel connection profiles with a sealing compound.
- The side walls made of magnesium-zinc sheet steel are riveted onto the connection profiles.

Standard construction type, construction type C

The side walls of the casing have a double-folded edge. This facilitates the handling of the exchanger with lifting tools and enables control dampers to be mounted.

Construction type F

The side walls of the casing are flat. That creates more space for the exchanger package and thus greater performance.

2.3 Exchanger sizes and efficiency

The installed exchanger area and thus the plate spacing are the determining factors for the efficiency. Hoval offers several plate spacings for all exchanger sizes so that an optimum solution can be achieved for each project.

Efficiency / plate spacing	Gotthard				Construction
	055	065	075	085	
P1	2.9	3.1	3.5	4.1	
P3	-	-	-	-	
P5	2.3	2.5	2.7	3.0	
	110	130	150	170	
P1	2.9	3.1	3.5	4.1	
P3	2.6	2.8	3.1	3.6	
P5	2.3	2.5	2.7	3.0	
	-	195	225	255	
P1		3.1	3.5	4.1	
P3	-	2.9	3.2	3.7	
P5		2.5	2.7	3.0	

Table C1: Clear plate spacings for Gotthard exchangers (nominal values without material thickness in mm)

2.4 Exchanger width

The width of the plate heat exchangers can be selected in steps of 1 mm. In order to simplify transport and installation, very wide exchangers are delivered in several parts. Several exchangers with dampers are linked with connecting bolts when installed into the air handling unit. Connecting bolts are also supplied.

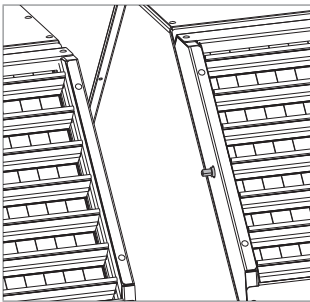

Fig. C6: Connecting bolts for damper connection for partitioned exchangers

3 Specification text

Hoval plate heat exchanger design G (Gotthard)

Hoval counter-flow plate heat exchanger for energy recovery, consisting of the exchanger package and the casing. The exchanger package consists of aluminium plates with pressed-in spacers; condensate drainage is possible in every direction, depending on the installation position. The plates are connected by a double fold, which gives a several-fold material thickness at air entry and exit. The corners of the exchanger package are sealed into especially rigid magnesium-zinc sheet steel connection profiles in the casing with a sealing compound. The side walls of magnesium-zinc sheet steel are riveted tightly to these extrusions. From size 110, these are combi blocks, each composed of 2 or 3 single exchangers and 2 air guides.

All performance data is certified by Eurovent and TÜV Süd. The suitability of the exchangers for use both in general ventilation technology and in hospitals is certified by independent test institutes.

Series

- V: Aluminium plates and magnesium-zinc sheet steel; differential pressure stability: max. 2000 Pa; silicone-free; resistant to temperatures up to 90 °C
- G: Coated aluminium plates, coated magnesium-zinc sheet steel and coated connection profiles; differential pressure stability: max. 2000 Pa; silicone-free; resistant to temperatures up to 90 °C.

Construction types

- -: Double-folded edges on side walls (standard)
- C: Combi block with double-folded edges on side walls
- F: Flat side walls (without bypass and dampers, up to size G-085)

Options

- Side or middle bypass: suited to the exchanger package.
- Control dampers: installed in front of exchanger package and bypass; damper blades made of aluminium (sizes G-055 to G-085) or sheet steel (sizes G-110 to G-255), magnesium-zinc sheet steel housing; polypropylene plastic drive gears outside the air flow; leak-tightness class 2 according to EN 1751; series G is powder-coated.
- Side or middle recirculation bypass: suited to exchanger package; incl. control dampers and recirculation damper with damper blades made of aluminium (sizes G-055 to G-085) or sheet steel (sizes G-110 to G-255), magnesium-zinc sheet steel casing; polypropylene plastic drive gears outside the air flow; leak-tightness class 2 according to EN 1751; series G is powder-coated.
- Horizontal installation: plates arranged horizontally (with middle bypass: max. width 2000 mm).
- Adapter for actuator: for inside drive of the control and recirculation dampers.
- Combi block supplied loose: single exchangers and air guides supplied loose, assembly on site.

4 Technical data

4.1 Application limits

Gotthard	Series V, G
Temperature	
Exchanger	-40 ... 90 °C
Dampers	-40 ... 80 °C
Max. differential pressure	2000 Pa

Table C2: Application limits

4.2 Specification of material

Series	V	G
Exchanger		
Plates	Aluminium	Aluminium epoxy-coated
Side walls	Magnesium zinc sheet	Magnesium-zinc sheet steel, powder-coated ¹⁾
Air guide	Magnesium zinc sheet	Magnesium-zinc sheet steel, powder-coated ¹⁾
Connection profiles	Magnesium zinc sheet steel or extruded aluminium section	Magnesium zinc sheet steel or extruded aluminium section, powder-coated ¹⁾
Seal	Silicone-free 2-component-adhesive	Silicone-free 2-component-adhesive
Rivets ²⁾	Aluminium	Aluminium
Dampers + adapter		
Casing	Magnesium zinc sheet	Magnesium-zinc sheet steel, powder-coated ¹⁾
Damper blades	Extruded aluminium section or galvanised sheet steel	Extruded aluminium section or galvanised sheet steel, powder-coated ¹⁾
Bearing	Aluminium	Aluminium
End caps, gear wheels	Polypropylene	Polypropylene

1) All powder coatings in red (RAL 3000)
2) Between side walls and connection profiles/plates

Table C3: Specification of material

4.3 Sound attenuation

Efficiency / plate spacing	Gotthard										
	055	065	075	085	110	130	150	170	195	225	255
P1	6.4	6.8	6.9	7.0	6.6	7.0	7.1	7.2	7.2	7.3	7.4
P3	–	–	–	–	7.6	8.0	8.8	9.0	7.8	8.4	8.7
P5	8.4	8.7	10.3	10.4	8.5	8.9	10.5	10.8	9.1	10.6	11.2

Table C4: Sound attenuation at 1000 Hz (values in dB)

Hz	63	125	250	500	1000	2000	4000	8000
f	0.24	0.48	0.67	0.85	1.00	1.15	1.27	1.36

Table C5: Frequency correction factors



Notice

For more information about sound attenuation see chapter 9 in the System design section.

4.4 Exchanger widths

Gotthard exchangers without bypass			Gotthard exchangers with middle bypass	
	055 - 170 200 ... 1200	195 - 255 500 ... 1200		500 ... 1200
	1201 ... 2400			1201 ... 1840
	2401 ... 3600			1841 ... 3000
	3601 ... 4800			(depending on the bypass width)
Gotthard exchangers with side bypass				
BS 	XS 	500 ... 1200		
BS 	XS 	1201 ... 2400		
Inside bypass width		7 % – 30 %		
			Inside bypass width	7 % – 30 % (max. 999 mm)

Table C6: Exchanger widths in mm (can be selected in steps of 1 mm)

4.5 Exchanger dimensions

Standard construction type

(= with side walls with double-folded edges)

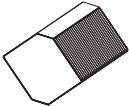
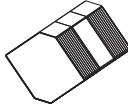
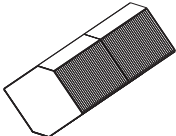
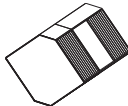
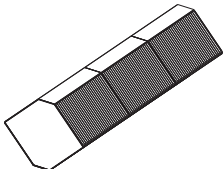
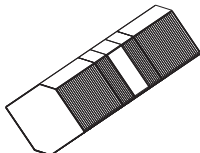
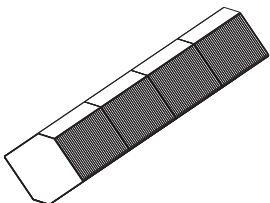
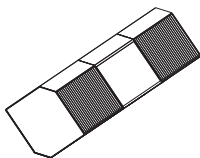
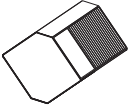
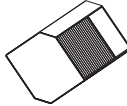
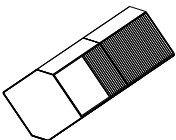
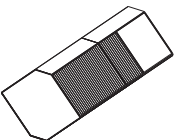
Size	055	065	075	085
H	533	674	815	957
D	758	899	1040	1182
A	335	435	535	635
ak	227	327	427	527
B	Exchanger width (outside dimension)			
S	Bypass width (inside width)			

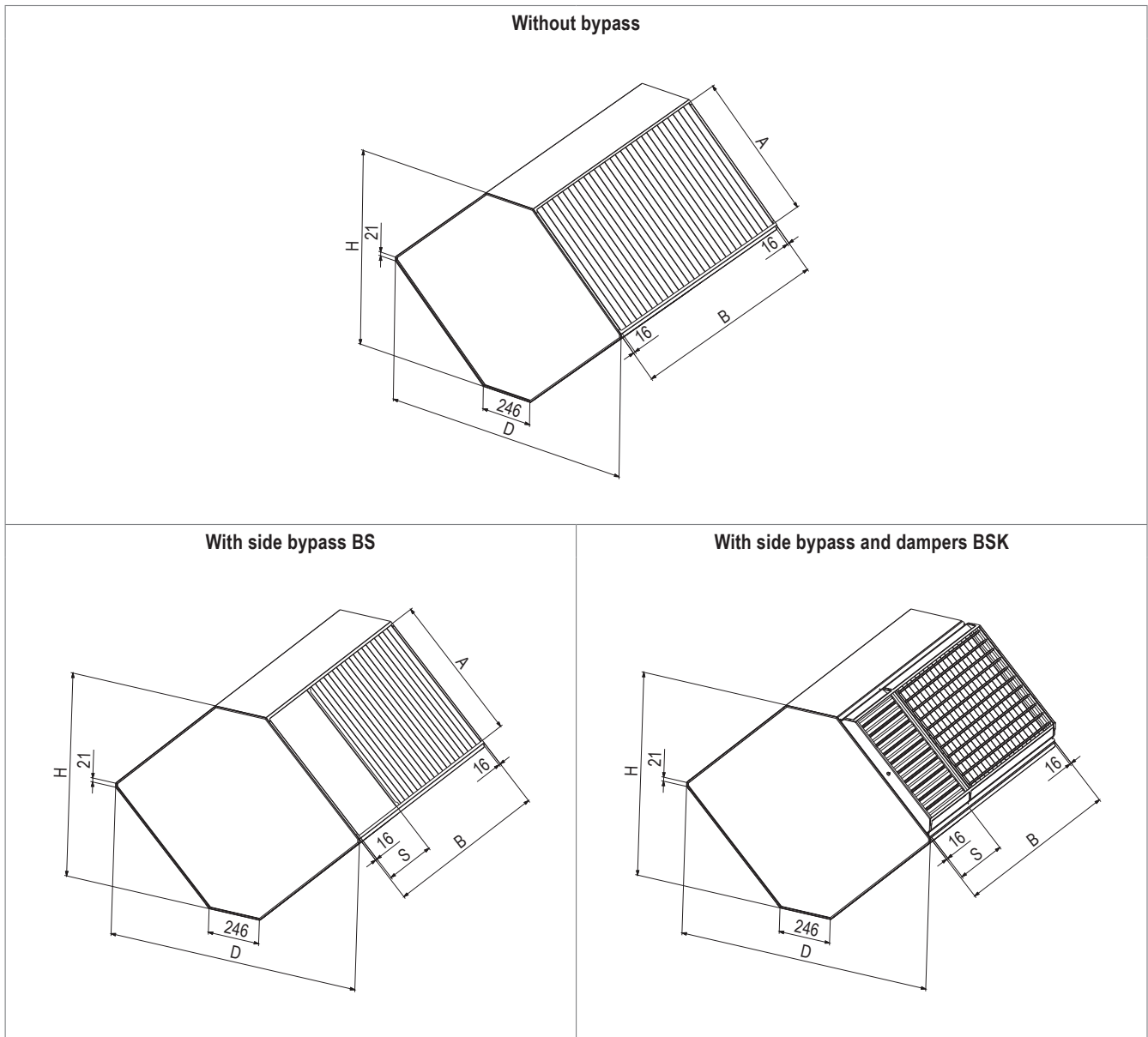

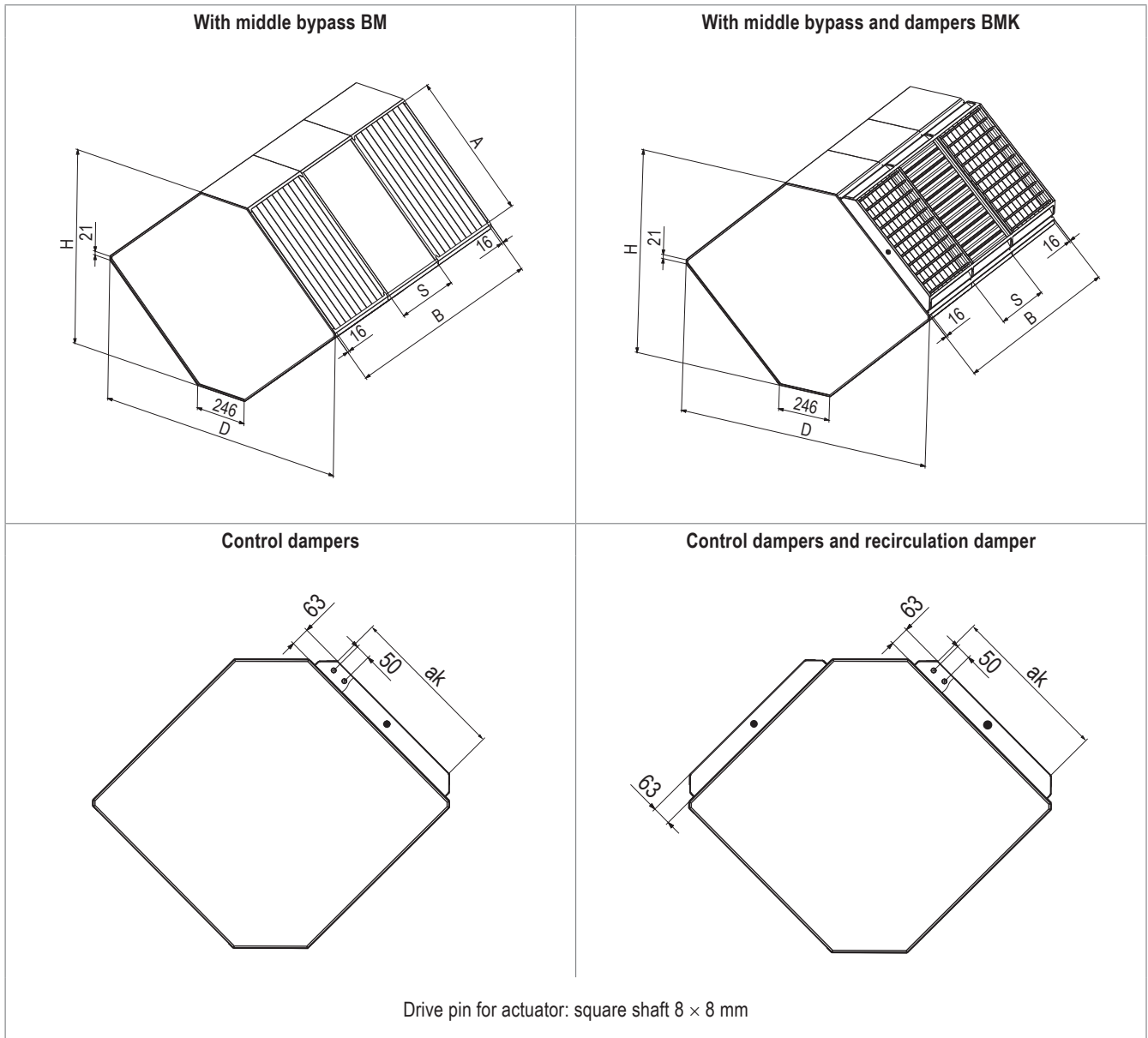
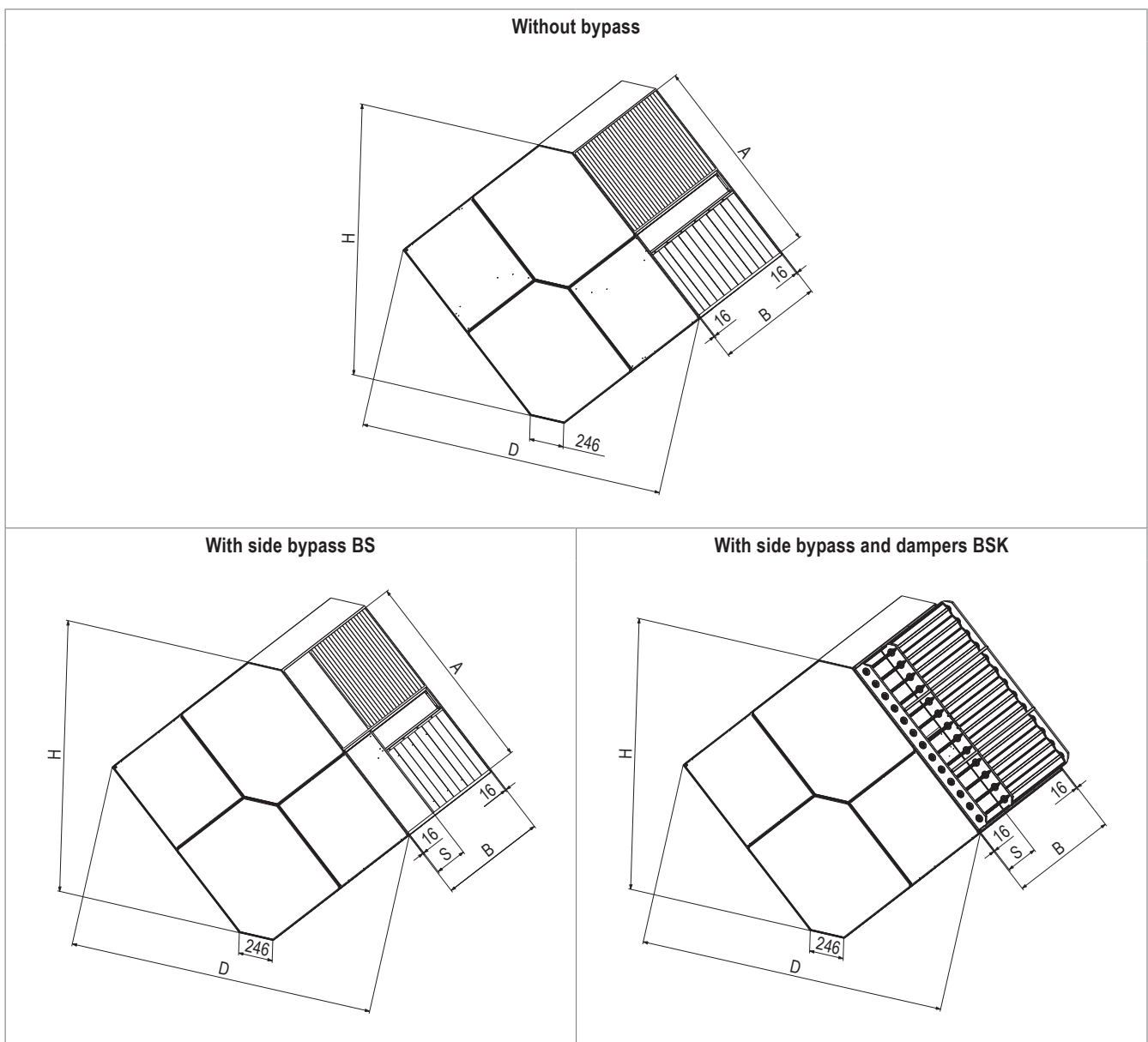

Fig. C7: Dimension sheet for Gotthard plate heat exchangers of the standard construction type (dimensions in mm)

Construction type C | sizes G-110 to G-170

(= combi block with side walls with double folded edges, composed of 2 single exchangers and 2 air guides)

Size	110	130	150	170
H	1068	1350	1632	1916
D	1313	1594	1876	2160
A	722	922	1122	1322
ak	716	916	1116	1316
B	Exchanger width (outside dimension)			
S	Bypass width (inside width)			



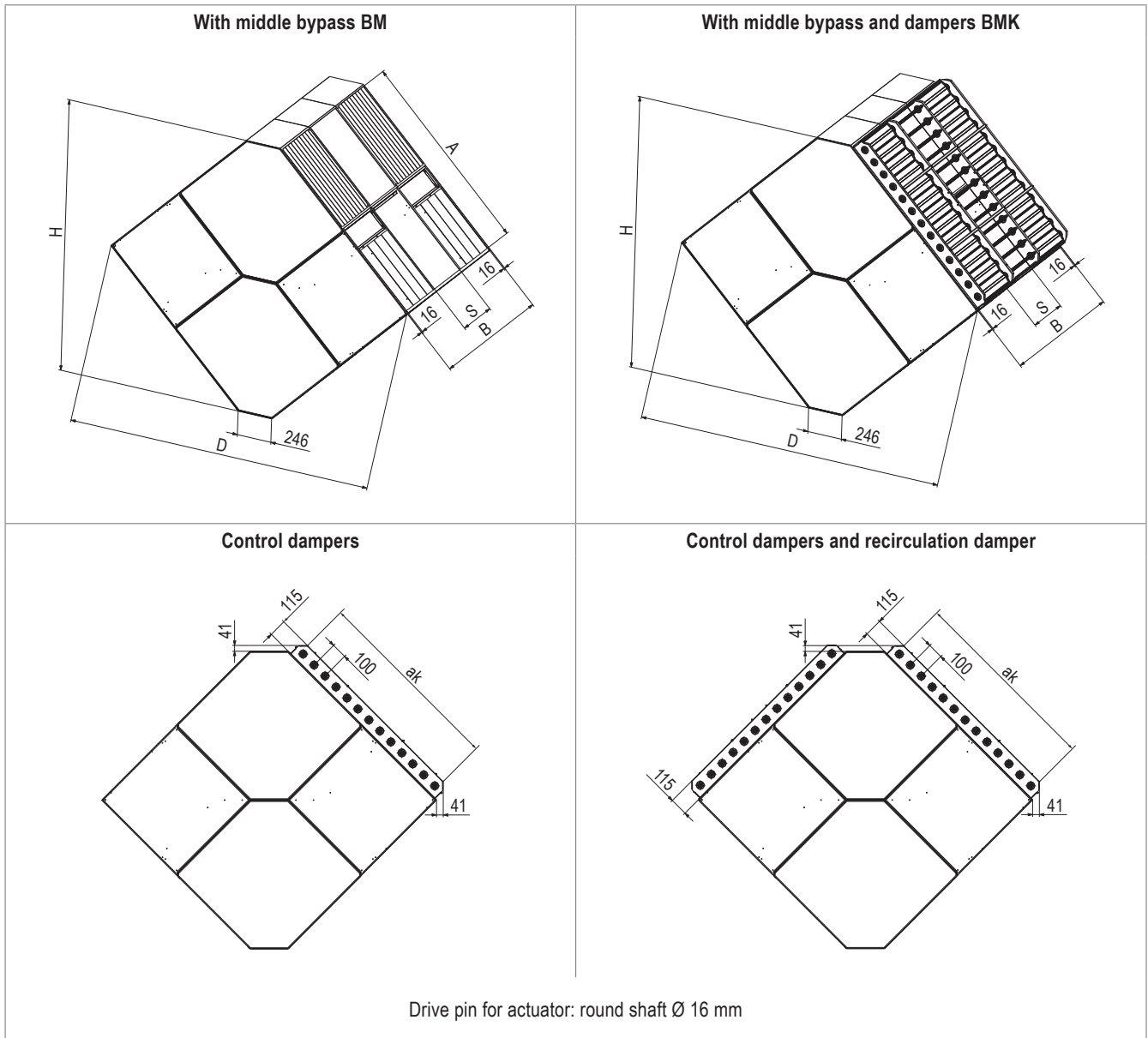
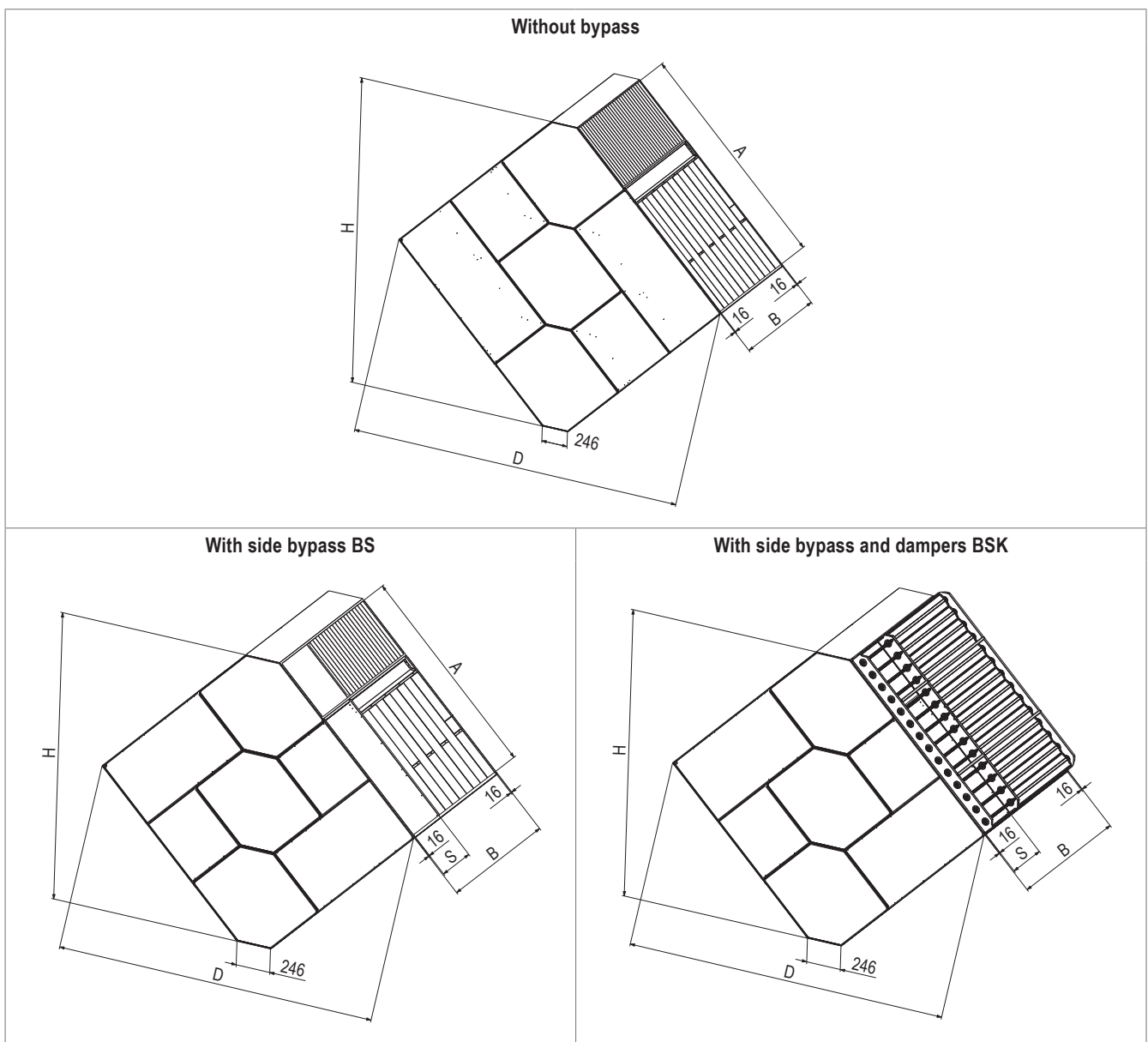

Fig. C8: Dimension sheet for Gotthard plate heat exchangers of construction type C (dimensions in mm)

Construction type C | sizes G-195 to G-255

(= combi block with side walls with double folded edges, composed of 3 single exchangers and 2 air guides)

Size	195	225	255
H	2027	2450	2876
D	2270	2701	3123
A	1401	1702	2003
ak	1418	1690	1990
B	Exchanger width (outside dimension)		
S	Bypass width (inside width)		



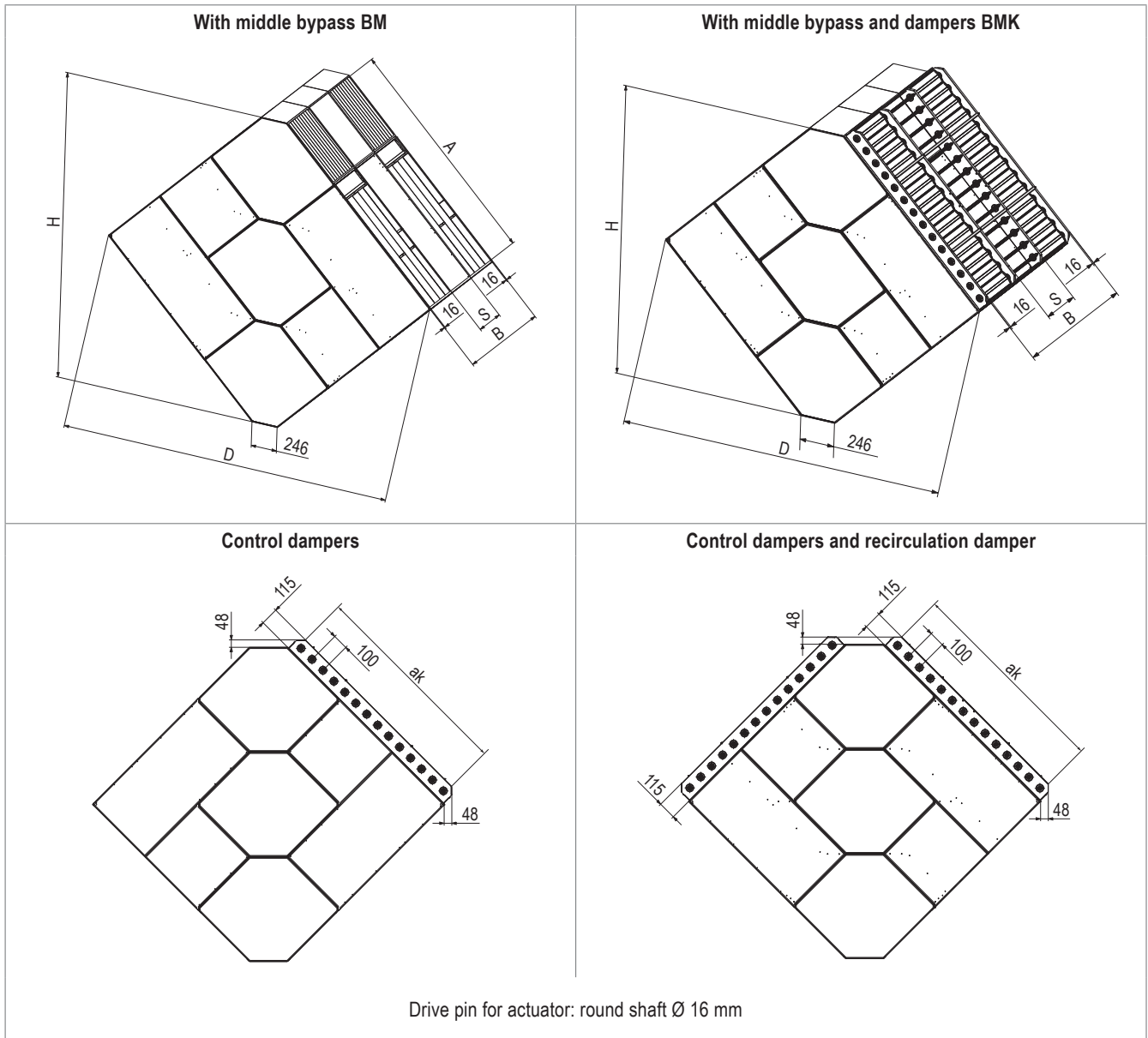

Fig. C9: Dimension sheet for Gotthard plate heat exchangers of construction type C (dimensions in mm)

Construction type F
 (= with flat side walls)

Size	055	065	075	085
H	533	674	815	957
D	758	899	1040	1182
A	361	461	561	661
B	Exchanger width (outside dimension)			

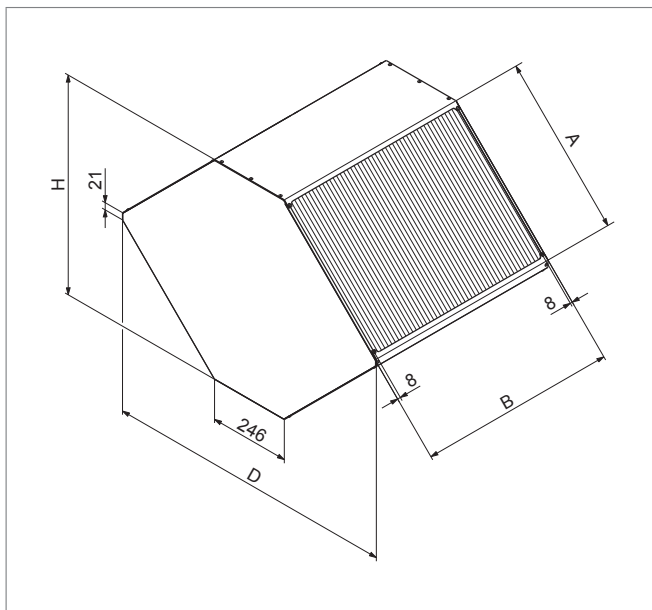

Fig. C10: Dimension sheet for Gotthard plate heat exchangers of construction type F (dimensions in mm)



Krivan – design K

Plate heat exchangers for air flow rates from 200...100 000 m³/h

1 Use26
2 Construction.26
3 Specification text.28
4 Technical data29



1 Use

Hoval plate heat exchangers of design K (Krivan) are energy recovery units for installation in ventilation and air-conditioning units. They are available in different sizes, suitable for air flow rates from approx. 200 to 100000 m³/h.

The suitability of the heat exchangers for use both in general ventilation technology and in hospitals is certified by independent test institutes.

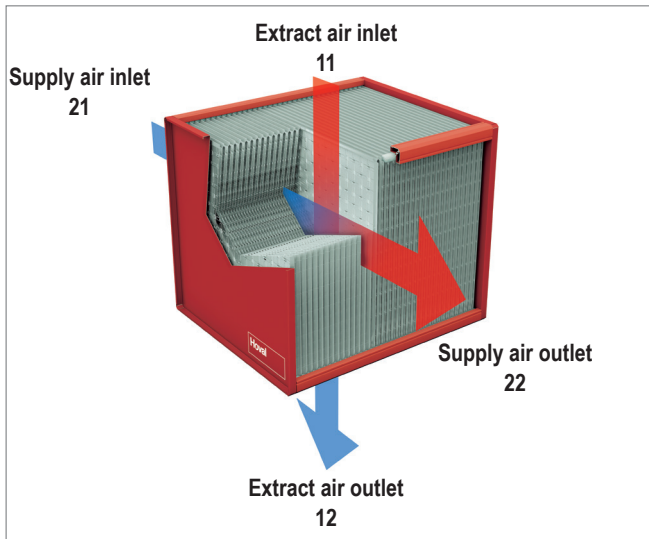
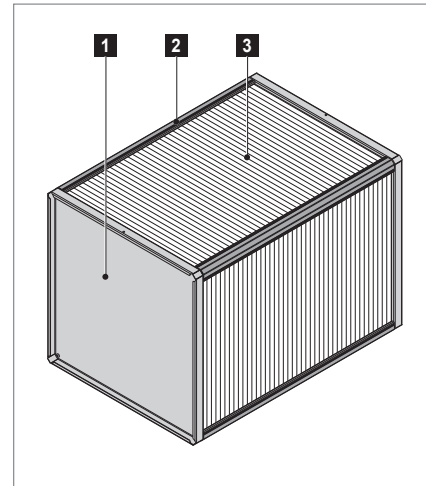

Fig. D1: Air flow through Krivan plate heat exchanger

Definition of temperature efficiency
$\eta_t = \frac{t_{22} - t_{21}}{t_{11} - t_{21}}$

2 Construction

Krivan plate heat exchangers consist of the exchanger package and the casing.



- 1 Side wall
- 2 Corner section
- 3 Exchanger package

Fig. D2: Structure of Krivan plate heat exchanger

2.1 Exchanger package

The exchanger package consists of specially formed aluminium plates. The surface profile has been designed and extensively tested to provide maximum efficiency. The focus was on performance: Krivan plate exchangers offer an optimal ratio between thermal efficiency and pressure drop. The main advantages are:

- High thermal efficiency with low pressure drop at the same time
- Very high differential pressure stability due to optimised arrangement of longitudinal and transverse ribs
- Condensate can drain freely in all directions

There are different plate sizes, which are formed with different profile depths, i.e. for different plate spacings and thus different efficiency values.

The connection of the plates is made by a double fold. This gives a several-fold material thickness at air entry and exit, which lends the exchanger package a particularly high stability and leak-tightness.

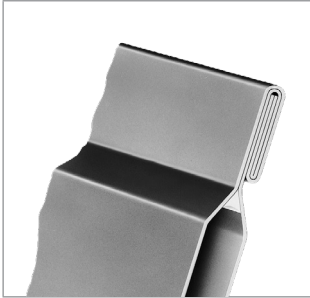

Fig. D3: Double fold connections give the exchanger package several-fold material thickness for the leading and trailing edges

2.2 Casing

The exchanger package is fitted into a casing consisting of corner sections and side walls.

- The corners of the exchanger package are sealed into the aluminium corner sections with a sealing compound.
- The side walls made of magnesium-zinc sheet steel are bolted onto the corner sections.
- The 45° corners facilitate installation and reduce the diagonal dimension.
- Other components can be bolted or riveted directly to the corner sections.
- The double folding of the side walls facilitates the handling of the exchanger with lifting tools.

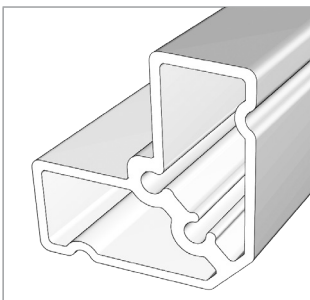

Fig. D4: The specially developed aluminium corner section offers particular advantages

2.3 Exchanger sizes and efficiency

The installed exchanger area and thus the plate spacing are the determining factors for the efficiency. Hoval offers several plate spacings for all exchanger sizes so that an optimum solution can be achieved for each project.



Efficiency / plate spacing	Krivan				
	085	100	140	170	200
P1	2.5	3.1	–	4.7	5.6
P3	2.5	3.1	–	–	–
PA	–	–	3.9	–	–
Construction					

Table D1: Clear plate spacings for Krivan exchangers (nominal values without material thickness in mm)

2.4 Exchanger width

The width of the plate heat exchangers can be selected in steps of 1 mm. In order to simplify transport and installation, very wide exchangers are delivered in 2 parts. Several exchangers with dampers are linked with connecting bolts when installed into the air handling unit. For this purpose, one or more connecting bolts are provided, depending on the exchanger size.



Notice

Depending on the exchanger size and width, several actuators are required to drive the control dampers and the recirculation damper and no connecting bolt is provided. For more information, see Table F1 and Table F2 in the Options section.

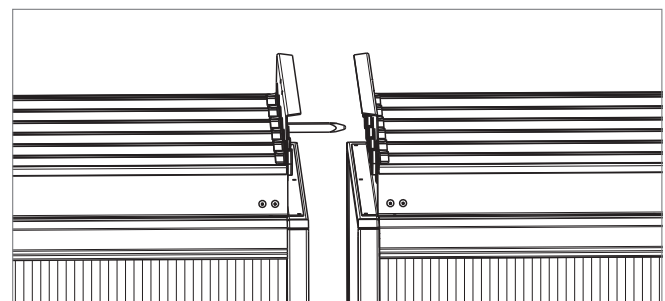

Fig. D5: Connecting bolts for damper connection for partitioned exchangers

3 Specification text

Hoval plate heat exchanger design K (Krivan)

Hoval crossflow plate heat exchangers for energy recovery, consisting of the exchanger package and the casing. The exchanger package consists of specially formed aluminium plates. The surface profile has been designed and extensively tested to provide maximum efficiency. The focus was on performance: Krivan plate exchangers offer an optimal ratio between thermal efficiency and pressure drop. The plates are connected by a double fold, which gives a several-fold material thickness at air entry and exit. The corners of the exchanger package are sealed into especially rigid aluminium extrusions in the casing with a sealing compound. The side walls of magnesium-zinc sheet steel are bolted tightly to these extrusions. All performance data is certified by Eurovent and TÜV Süd. The suitability of the exchangers for use both in general ventilation technology and in hospitals is certified by independent test institutes.

Series

- V: Aluminium plates, magnesium-zinc sheet steel and aluminium corner sections; differential pressure stability: max. 2500 Pa; silicone-free; resistant to temperatures up to 90 °C.
- G: Coated aluminium plates, coated magnesium-zinc sheet steel and coated corner sections; differential pressure stability: max. 2500 Pa; silicone-free; resistant to temperatures up to 90 °C.

Construction types

- -: Individual plate heat exchanger (standard)
- Z: Twin plate heat exchanger – 2 single plate heat exchangers, optionally without bypass, with bypass or with bypass and dampers. If dampers are ordered, they are only mounted on one of the two exchangers. Assembled on site in the air handling unit.

Options

- Side or middle bypass: suited to the exchanger package.
- Control dampers: installed in front of exchanger package and bypass; sheet steel damper blades, magnesium-zinc sheet steel housing, drive gears outside the air flow (available in either polypropylene or aluminium); leak-tightness class 2 according to EN 1751; series G is powder-coated.
- Side or middle recirculation bypass: suited to exchanger package; incl. control dampers and recirculation damper with sheet steel damper blades, magnesium-zinc sheet steel casing and drive gears outside the air flow (available in either polypropylene or aluminium); leak-tightness class 2 according to EN 1751; series G is powder-coated.
- Leak-tightness test: additional sealing with casting resin; thus extremely watertight design; incl. water test.
- Horizontal installation: plates arranged horizontally.

- Adapter for actuator: for inside drive of the control and recirculation dampers.
- Reinforced packaging: additional wooden crate on top, 4-sided covering of the exchanger package with wood fibre boards, machine wrapping foil.
- Block of 4 supplied loose: exchanger sizes composed of 4 packages, supplied loose, assembly on site.

4 Technical data

4.1 Application limits

Krivan	Series V, G
Temperature	
Exchanger	-40 ... 90 °C
Dampers	-40 ... 80 °C
Max. differential pressure	2500 Pa

Table D2: Application limits

4.2 Specification of material

Series	V	G
Exchanger		
Plates	Aluminium	Aluminium epoxy-coated
Side walls	Magnesium zinc sheet	Magnesium-zinc sheet steel, powder-coated ¹⁾
Corner sections	Extruded aluminium section	Extruded aluminium section, powder-coated ¹⁾
Seal	Silicone-free 2-component-adhesive	Silicone-free 2-component-adhesive
Screws ²⁾	Galvanised steel	Chromium steel
Dampers + adapter		
Casing	Magnesium zinc sheet	Magnesium-zinc sheet steel, powder-coated ¹⁾
Damper blades	Galvanised sheet steel	Galvanised sheet steel, powder-coated ¹⁾
Bearing, end caps, gear wheels	Polypropylene or aluminium	Polypropylene or aluminium

¹⁾ All powder coatings in red (RAL 3000)

²⁾ Between side walls and corner sections

Table D3: Specification of material

4.3 Sound attenuation

Efficiency / plate spacing	Krivan				
	085	100	140	170	200
P1	11.8	11.5	–	11.0	10.7
P3	11.8	11.5	–	–	–
PA	–	–	11.9	–	–

Table D4: Sound attenuation at 1000 Hz (values in dB)

Hz	63	125	250	500	1000	2000	4000	8000
f	0.24	0.48	0.67	0.85	1.00	1.15	1.27	1.36

Table D5: Frequency correction factors



Notice

For more information about sound attenuation see chapter 9 in the System design section.

4.4 Exchanger widths



Krivan	085 - 100	140 - 200
Exchangers with/without bypass		
	200 ... 2050	–
	2051 ... 4100	–
	–	200 ... 2050
	–	2051 ... 4100
Inside bypass width	50 ... 999	50 ... 999

Table D6: Exchanger widths in mm (can be selected in steps of 1 mm)

4.5 Exchanger dimensions

Exchangers without dampers

Size	085	100	140	170	200
H = L	840	990	1380	1680	1980
D	1175	1387	1939	2363	2787
B	Exchanger width (outside dimension)				
S	Bypass width (inside width)				

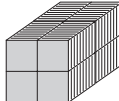
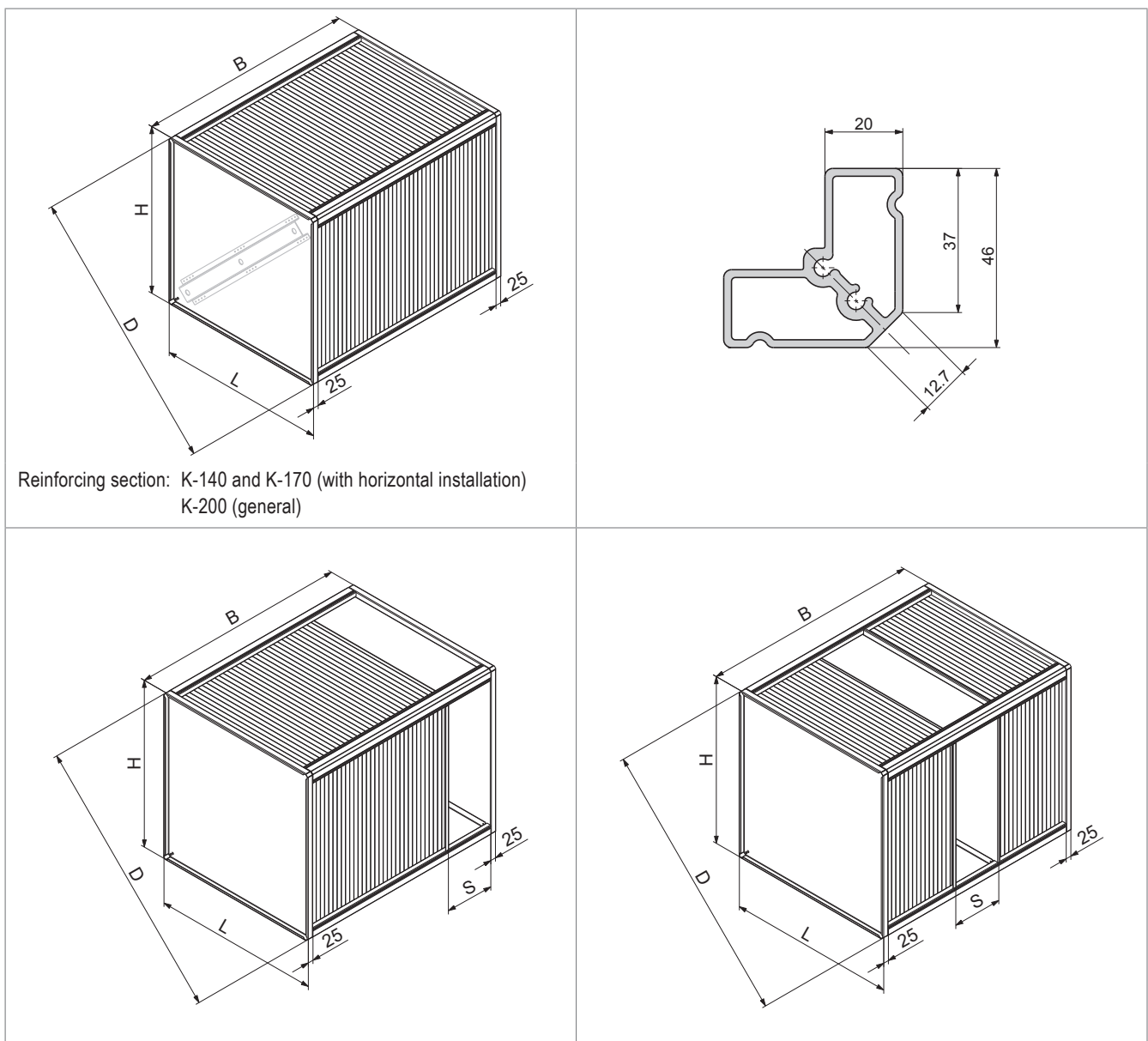

Fig. D6: Dimension sheet for Krivan plate heat exchangers without dampers (dimensions in mm)

Exchangers with dampers

Size	085	100	140	170	200
H = L	840	990	1380	1680	1980
D	1175	1387	1939	2363	2787
X	16	34	37	37	34
B	Exchanger width (outside dimension)				
S	Bypass width (inside width)				

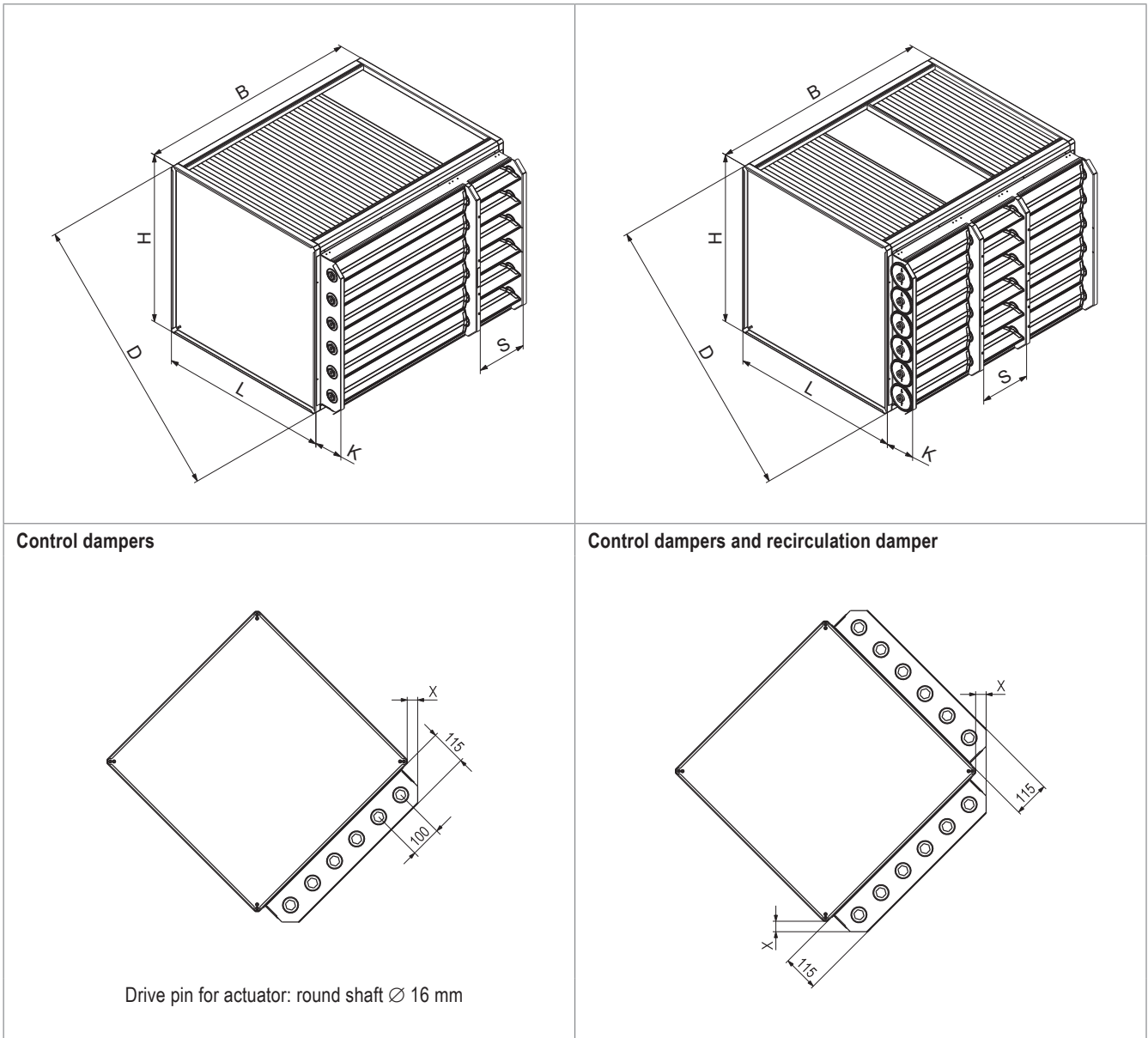
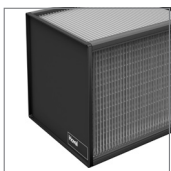

Fig. D7: Dimension sheet for Krivan plate heat exchangers with dampers (dimensions in mm)



Design S

Plate heat exchangers for air flow rates from 200...100 000 m³/h

1 Use34
2 Construction.34
3 Specification text.36
4 Technical data37



1 Use

Hoval plate heat exchangers of design S are energy recovery units for installation in ventilation and air-conditioning units. They are available in different sizes, suitable for air flow rates from approx. 200 to 100000 m³/h.

The suitability of the heat exchangers for use both in general ventilation technology and in hospitals is certified by independent test institutes.

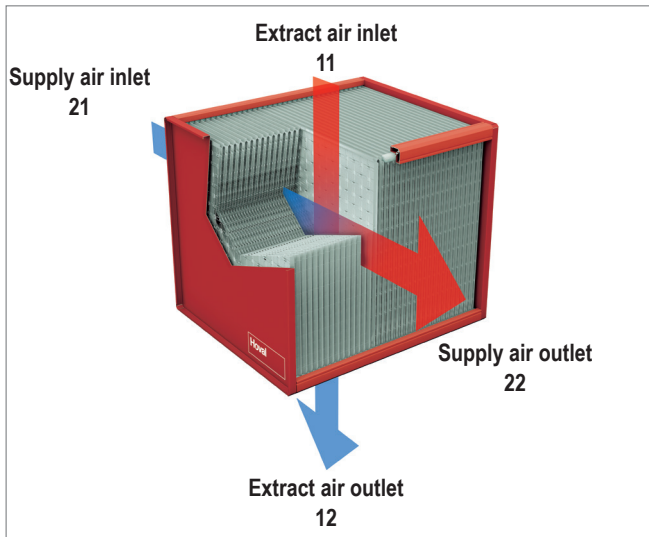

Fig. E1: Air flow through design S plate heat exchanger

Definition of temperature efficiency

$$\eta_t = \frac{t_{22} - t_{21}}{t_{11} - t_{21}}$$

2 Construction

Design S plate heat exchangers consist of the exchanger package and the casing.

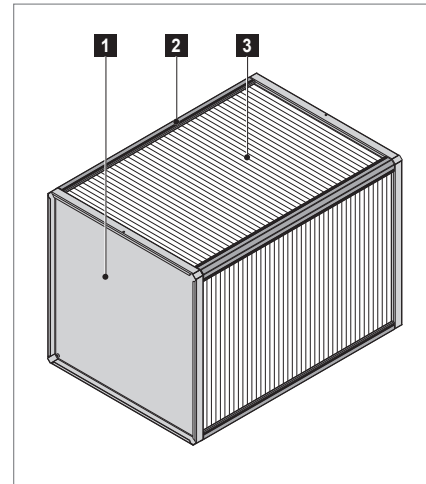

- 1 Side wall
- 2 Corner section
- 3 Exchanger package

Fig. E2: Structure of design S plate heat exchanger

2.1 Exchanger package

The exchanger package consists of specially formed aluminium plates. Their profile is an optimum design resulting from detailed tests for temperature efficiency, pressure drop and rigidity.

There are different plate sizes, which are formed with different profile depths, i.e. for different plate spacings and thus different efficiency values.

The connection of the plates is made by a double fold. This gives a several-fold material thickness at air entry and exit, which lends the exchanger package a particularly high stability and leak-tightness.



Fig. E3: Double fold connections give the exchanger package several-fold material thickness for the leading and trailing edges

2.2 Casing

The exchanger package is fitted into a casing consisting of corner sections and side walls.

- The corners of the exchanger package are sealed into the aluminium corner sections with a sealing compound.
- The side walls made of magnesium-zinc sheet steel are bolted onto the corner sections.
- The 45° corners facilitate installation and reduce the diagonal dimension.
- Other components can be bolted or riveted directly to the corner sections.
- The double folding of the side walls facilitates the handling of the exchanger with lifting tools.

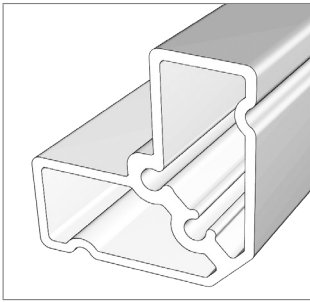

Fig. E4: The specially developed aluminium corner section offers particular advantages

2.3 Exchanger sizes and efficiency

The installed exchanger area and thus the plate spacing are the determining factors for the efficiency. Hoval offers several plate spacings for all exchanger sizes so that an optimum solution can be achieved for each project.



Efficiency / plate spacing	Design S									
	050	060	070	085	100	120	140	170	200	240
-A	2.0	2.0	2.0	-	-	3.2	-	-	-	-
-C	-	-	2.0	-	-	-	-	2.0	-	-
AD	-	2.5	-	-	-	-	-	-	-	-
-D	-	-	-	-	-	-	-	-	-	-
-E	-	-	2.0	-	-	3.2	-	-	6.3	6.3
-R	-	-	-	3.9	-	3.2	-	3.9	-	-
AS	-	-	-	-	3.5	-	-	-	-	-
AX	-	-	-	5.1	-	4.8	-	-	-	-
-X	-	-	-	5.1	4.4	-	4.3	5.1	-	-
AL	-	4.7	5.3	6.3	6.3	6.3	-	6.3	6.3	6.3
-L	4.4	-	-	6.3	6.3	6.3	-	6.3	6.3	6.3
AW	-	6.3	6.3	-	-	-	6.3	-	-	-
-W	-	6.3	6.3	-	-	-	6.3	-	-	-
Construction										

Table E1: Clear plate spacings for design S exchangers (nominal values without material thickness in mm)

2.4 Exchanger width

The width of the plate heat exchangers can be selected in steps of 1 mm. In order to simplify transport and installation, very wide exchangers are delivered in parts. Several exchangers with dampers are linked with connecting bolts when installed into the air handling unit. For this purpose, one or more connecting bolts are provided, depending on the exchanger size.



Notice

Depending on the exchanger size and width, several actuators are required to drive the control dampers and the recirculation damper and no connecting bolt is provided. For more information, see Table F1 and Table F2 in the Options section.

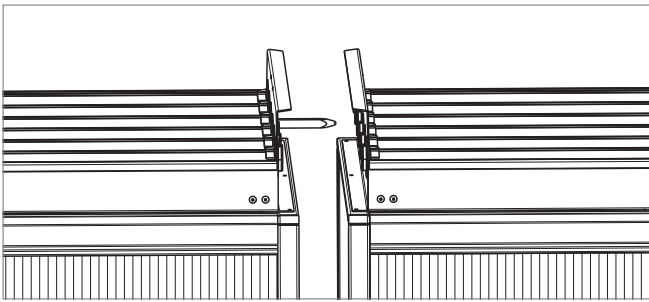

Fig. E5: Connecting bolts for damper connection for partitioned exchangers

3 Specification text

Hoval plate heat exchanger design S

Hoval crossflow plate heat exchangers for energy recovery, consisting of the exchanger package and the casing. The exchanger package consists of aluminium plates with pressed-in spacers; condensate drainage is possible in every direction, depending on the installation position. The plates are connected by a double fold, which gives a several-fold material thickness at air entry and exit. The corners of the exchanger package are sealed into especially rigid aluminium extrusions in the casing with a sealing compound. The side walls of magnesium-zinc sheet steel are bolted tightly to these extrusions. All performance data is certified by Eurovent and TÜV Süd. The suitability of the exchangers for use both in general ventilation technology and in hospitals is certified by independent test institutes.

Series

- V: Aluminium plates, magnesium-zinc sheet steel and aluminium corner sections; differential pressure stability: max. 2500 Pa; silicone-free; resistant to temperatures up to 90 °C.
- G: Coated aluminium plates, coated magnesium-zinc sheet steel and coated corner sections; differential pressure stability: max. 2500 Pa; silicone-free; resistant to temperatures up to 90 °C.

Construction types

- -: Individual plate heat exchanger (standard)
- Z: Twin plate heat exchanger – 2 single plate heat exchangers, optionally without bypass, with bypass or with bypass and dampers. If dampers are ordered, they are only mounted on one of the two exchangers. Assembled on site in the air handling unit.

Options

- Side or middle bypass: suited to the exchanger package.
- Control dampers: installed in front of exchanger package and bypass; sheet steel damper blades, magnesium-zinc sheet steel housing, drive gears outside the air flow (available in either polypropylene or aluminium); leak-tightness class 2 according to EN 1751; series G is powder-coated.
- Side or middle recirculation bypass: suited to exchanger package; incl. control dampers and recirculation damper with sheet steel damper blades, magnesium-zinc sheet steel casing and drive gears outside the air flow (available in either polypropylene or aluminium); leak-tightness class 2 according to EN 1751; series G is powder-coated.
- Leak-tightness test: additional sealing with casting resin; thus extremely watertight design; incl. water test.
- Horizontal installation: plates arranged horizontally.
- Adapter for actuator: for inside drive of the control and recirculation dampers.
- Reinforced packaging: additional wooden crate on top, 4-sided covering of the exchanger package with wood fibre boards, machine wrapping foil.
- Block of 4 supplied loose: exchanger sizes composed of 4 packages, supplied loose, assembly on site.

4 Technical data

4.1 Application limits

Design S	Series V, G
Temperature	
Exchanger	-40 ... 90 °C
Dampers	-40 ... 80 °C
Max. differential pressure	2500 Pa

Table E2: Application limits

4.2 Specification of material

Series	V	G
Exchanger		
Plates	Aluminium	Aluminium epoxy-coated
Side walls	Magnesium zinc sheet	Magnesium-zinc sheet steel, powder-coated ¹⁾
Corner sections	Extruded aluminium section	Extruded aluminium section, powder-coated ¹⁾
Seal	Silicone-free 2-component-adhesive	Silicone-free 2-component-adhesive
Screws ²⁾	Galvanised steel	Chromium steel
Dampers + adapter		
Casing	Magnesium zinc sheet	Magnesium-zinc sheet steel, powder-coated ¹⁾
Damper blades	Galvanised sheet steel	Galvanised sheet steel, powder-coated ¹⁾
Bearing, end caps, gear wheels	Polypropylene or aluminium	Polypropylene or aluminium
¹⁾ All powder coatings in red (RAL 3000) ²⁾ Between side walls and corner sections		

Table E3: Specification of material

4.3 Sound attenuation

Efficiency / plate spacing	Design S									
	050	060	070	085	100	120	140	170	200	240
-A	8.3	9.9	11.6	-	-	12.4	-	-	-	-
-C	-	-	11.6	-	-	-	-	28.1	-	-
AD	-	7.9	-	-	-	-	-	-	-	-
-D	-	-	-	-	-	-	-	-	-	-
-E	-	-	11.6	-	-	12.4	-	-	10.5	12.6
-R	-	-	-	7.2	-	12.4	-	14.4	-	-
AS	-	-	-	-	10.3	-	-	-	-	-
AX	-	-	-	5.5	-	8.3	-	-	-	-
-X	-	-	-	5.5	7.5	-	10.7	11.0	-	-
AL	-	4.3	4.4	4.5	5.2	6.3	-	8.9	10.5	12.6
-L	3.8	-	-	4.5	5.2	6.3	-	8.9	10.5	12.6
AW	-	3.1	3.7	-	-	-	7.3	-	-	-
-W	-	3.1	3.7	-	-	-	7.3	-	-	-



Notice

For more information about sound attenuation see chapter 9 in the System design section.

Table E4: Sound attenuation at 1000 Hz (values in dB)

Hz	63	125	250	500	1000	2000	4000	8000
f	0.24	0.48	0.67	0.85	1	1.15	1.27	1.36

Table E5: Frequency correction factors

4.4 Exchanger widths



Design S	050 - 060	070 - 120	140 - 240
Exchangers with/without bypass			
	200 ... 1400	200 ... 2050	-
	1401 ... 2800	2051 ... 4100	-
	2801 ... 4100	-	-
	-	-	200 ... 2050
	-	-	2051 ... 4100
Inside bypass width	50 ... 999	50 ... 999	50 ... 999

Table E6: Exchanger widths in mm (can be selected in steps of 1 mm)

4.5 Exchanger dimensions

Exchangers without dampers

Size	050	060	070	085	100	120	140	170	200	240
H = L	467	567	690	840	990	1190	1380	1680	1980	2380
D	648	789	963	1175	1387	1670	1939	2363	2787	3353
B	Exchanger width (outside dimension)									
S	Bypass width (inside width)									

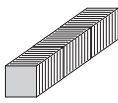
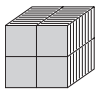
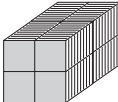
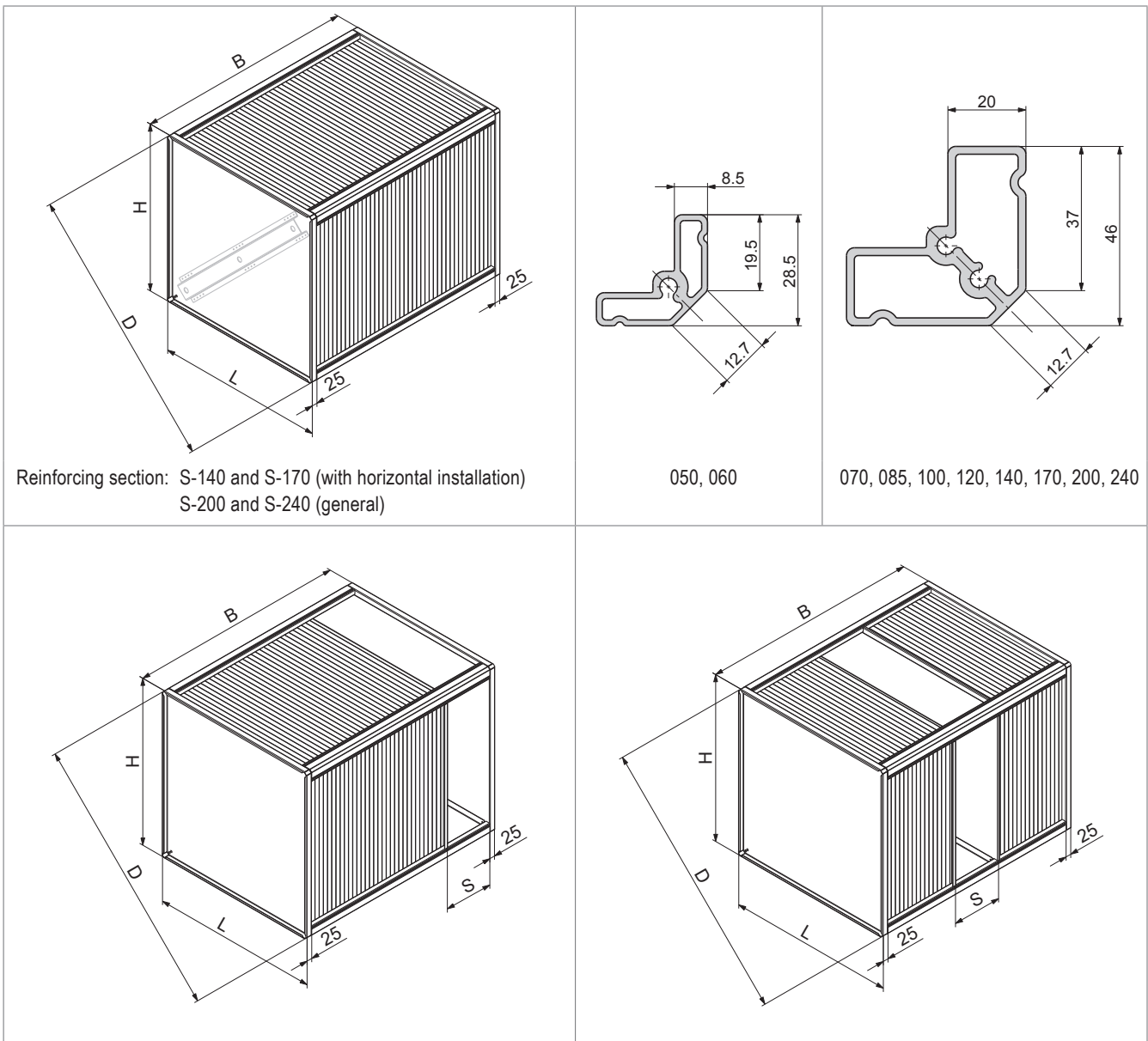

Fig. E6: Dimension sheet for design S plate heat exchangers without dampers (dimensions in mm)

Exchangers with dampers

Size	050	060	070	085	100	120	140	170	200	240
H = L	467	567	690	840	990	1190	1380	1680	1980	2380
D	648	789	963	1175	1387	1670	1939	2363	2787	3353
X	42	42	34	16	34	34	37	37	34	34
B	Exchanger width (outside dimension)									
S	Bypass width (inside width)									

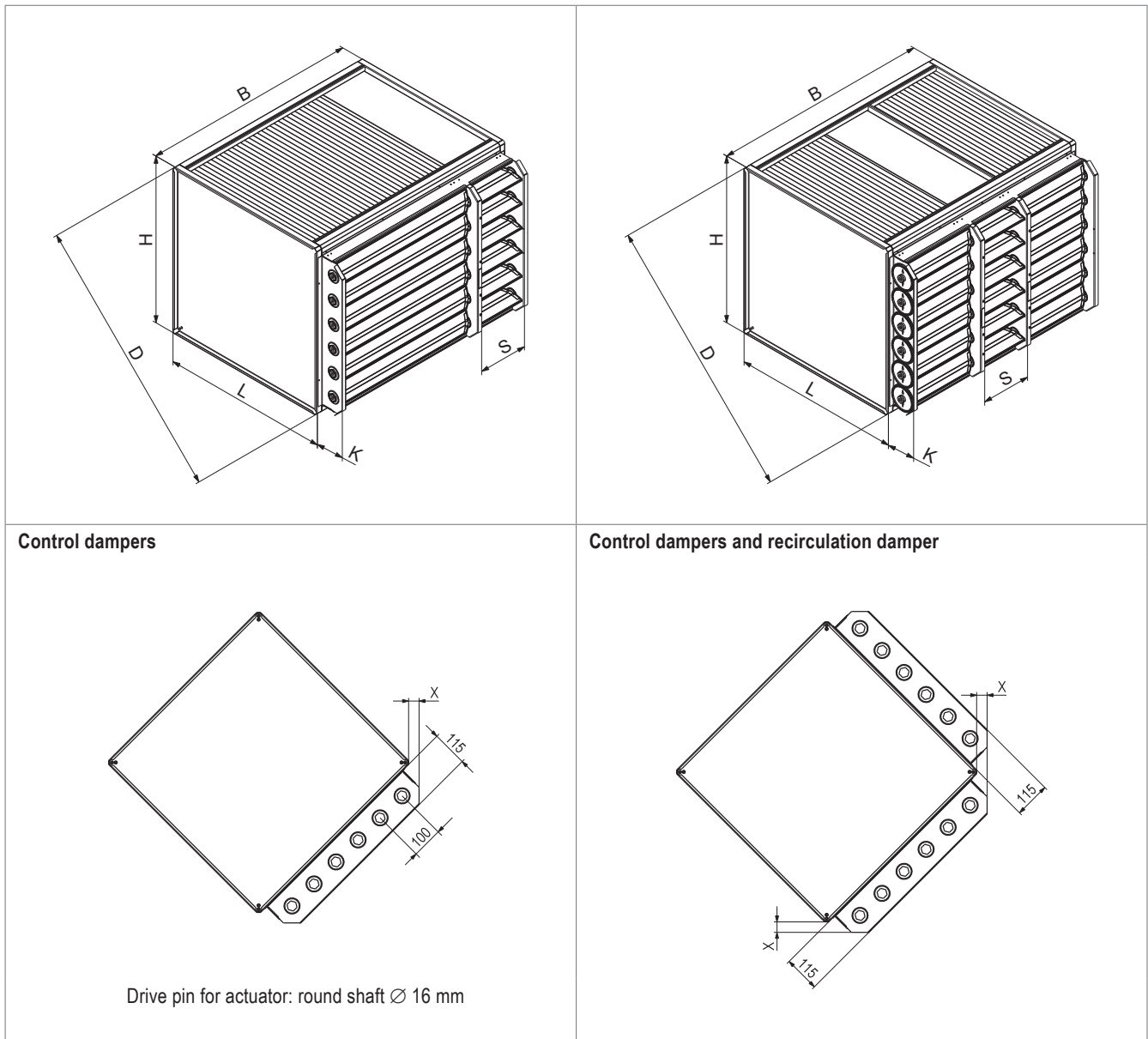

Fig. E7: Dimension sheet for design S plate heat exchangers with dampers (dimensions in mm)

1 Bypass.42
2 Control dampers43
3 Adapter for actuator44
4 Recirculation bypass45
5 Leakage test47
6 Horizontal installation47
7 Stronger packaging47
8 Block supplied loose48
9 Optimum order quantity48



Options



F

1 Bypass

A bypass is installed in the exchanger casing for controlling the performance of the plate heat exchanger; it can be built in at the side or in the middle. For aerodynamic reasons, Hoval recommends the central arrangement if the exchanger is 1500 mm wide or wider.

The CASER design program automatically calculates the bypass width so that the bypass has approximately the same pressure drop as the exchanger package. Of course, the bypass width can also be specified.

For installation in the ventilation unit, Hoval recommends arranging the bypass in the supply air flow. With this arrangement, freezing of the plate heat exchanger can be prevented if this becomes necessary at very low outside temperatures (defrost circuit).

If the plate heat exchanger is installed horizontally, the bypass must be positioned in the middle or at the top.

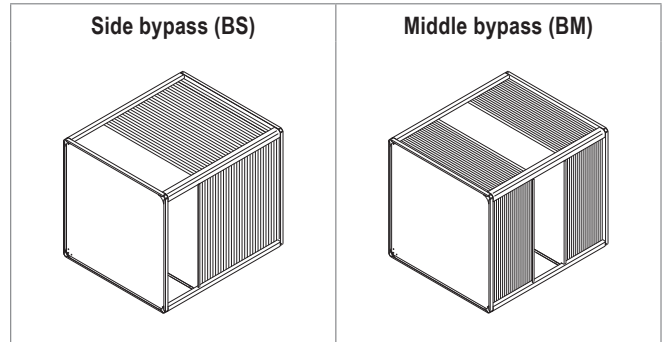

Fig. F1: Bypass arrangement in crossflow exchangers

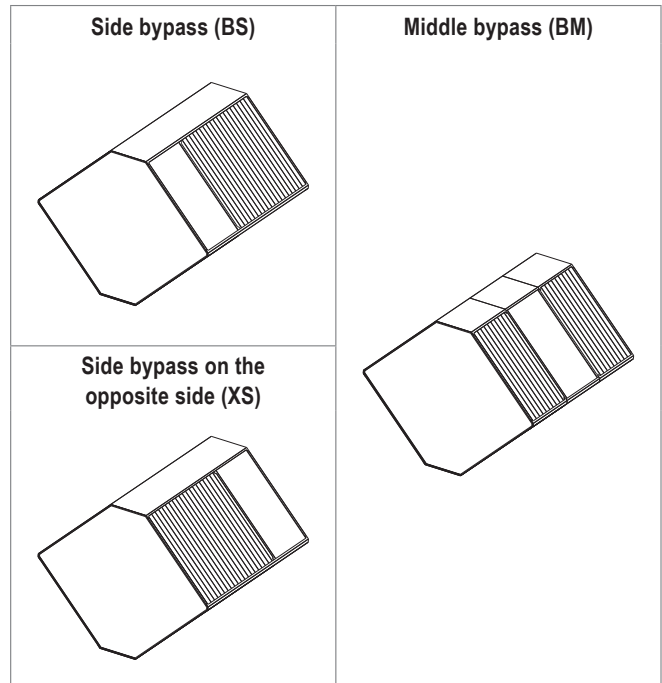

Fig. F2: Bypass arrangement in counterflow exchangers

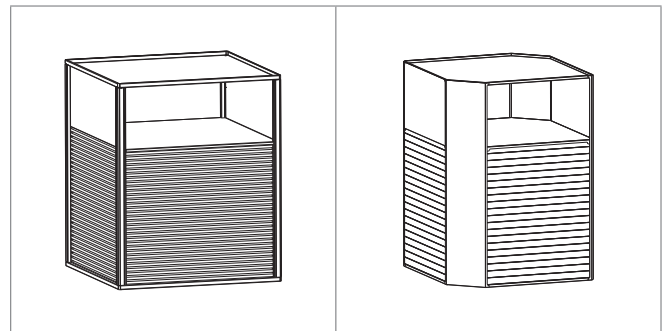

Fig. F3: Arrangement of a side bypass when installed horizontally

2 Control dampers

Opposed control dampers are required for performance control via bypass. They are mounted directly on the flange of the casing in front of the exchanger package and the bypass. The specially designed dampers are characterised by the following features:

- There is no narrowing of the cross-section of the air inlet opening.
- The gear wheels are protected from the air stream.
- Thanks to the space-saving design, the dampers are easy to integrate into the ventilation unit.

Depending on the exchanger size, one or more actuators are required to drive the dampers. Drive pins are supplied loose. Install them in the middle of the damper for an optimum force application. The required torque depends on the exchanger width.

The maximum damper blade width is 1200 mm; an intermediate bar is provided for bigger dimensions.

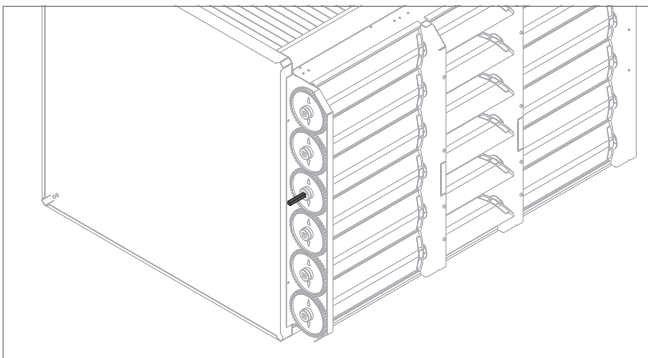

Fig. F4: Drive pin near the damper middle

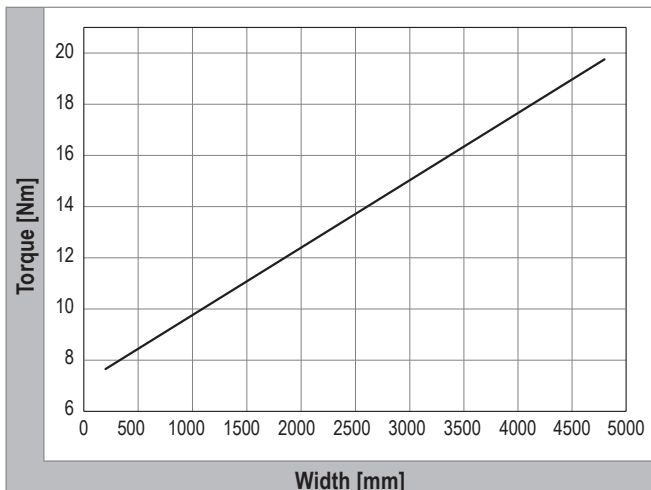

Fig. F5: Necessary torque per actuator

Design	Width (mm)	Quantity	
		Control dampers	Actuators
Side bypass			
G-055 ... G-195	500 ... 1200	1	1
	1201 ... 2400	2	1
G-225 ... G-255	500 ... 1200	2	2
	1201 ... 2400	4	2
Middle bypass			
G-055 ... G-195	500 ... 1200	1	1
	1201 ... 1845	2	1
	1846 ... 3000	3	2
	3001 ... 4800	5	3
G-225 ... G-255	500 ... 1200	2	2
	1201 ... 1845	4	2
	1846 ... 3000	6	4
	3001 ... 4800	10	6
Side or middle bypass			
K-085 ... K-140	200 ... 2050	1	1
	2051 ... 4100	2	1
K-170	200 ... 2050	1	1
	2051 ... 4100	2	2 ¹⁾
K-200	200 ... 2050	2	2
	2051 ... 4100	4	2
S-050 ... S-060	200 ... 1400	1	1
	1401 ... 2800	2	1
S-070 ... S-140	200 ... 2050	1	1
	2051 ... 4100	2	1
S-170	200 ... 2050	1	1
	2051 ... 4100	2	2 ¹⁾
S-200 ... S-240	200 ... 2050	2	2
	2051 ... 4100	4	2

¹⁾ The dampers cannot be linked with a connecting bolt across the width. 2 actuators are required.
²⁾ Only 2 of the 3 dampers can be linked with a connecting bolt across the width. 2 actuators are required.

Table F1: Number of actuators required

3 Adapter for actuator

The adapter for actuator enables dampers to be driven with commercially available actuators within a ventilation unit or duct (suitable for control and recirculation dampers). It is supplied loose for on-site mounting on the damper. The number of adapters supplied corresponds to the number of actuators required for the respective exchanger.

Please note the following:

- Check that there is sufficient space available.
- Install the adapter in the middle of the damper for an optimum force application. For this, the plate flange is cut out above a gear wheel so that the adapter gear wheel can be put on directly.
- Make sure that no electric cables obstruct the function of the dampers.
- On certain designs, the adapter protrudes beyond the outer edges of the exchanger (for dimensions, see Fig. F6 to Fig. F9).

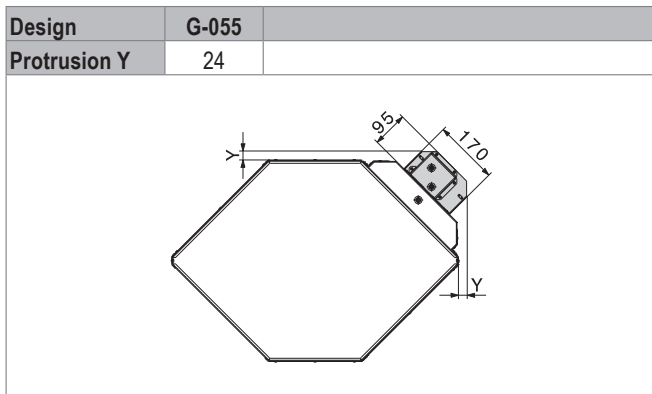

Fig. F6: Dimension sheet adapter for Gotthard G-055 (in mm)

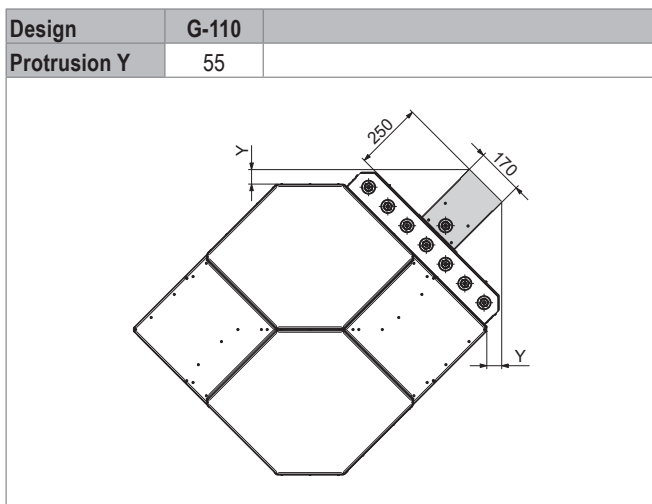

Fig. F7: Dimension sheet adapter for Gotthard G-110 (in mm)

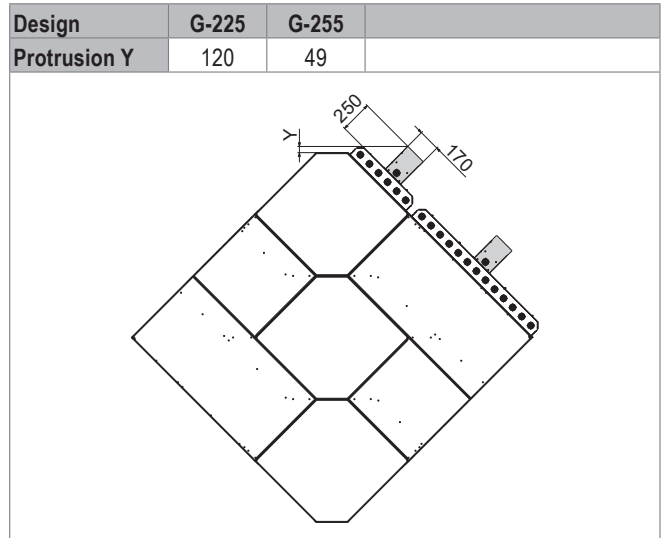

Fig. F8: Dimension sheet adapter for Gotthard G-225 and G-255 (in mm)

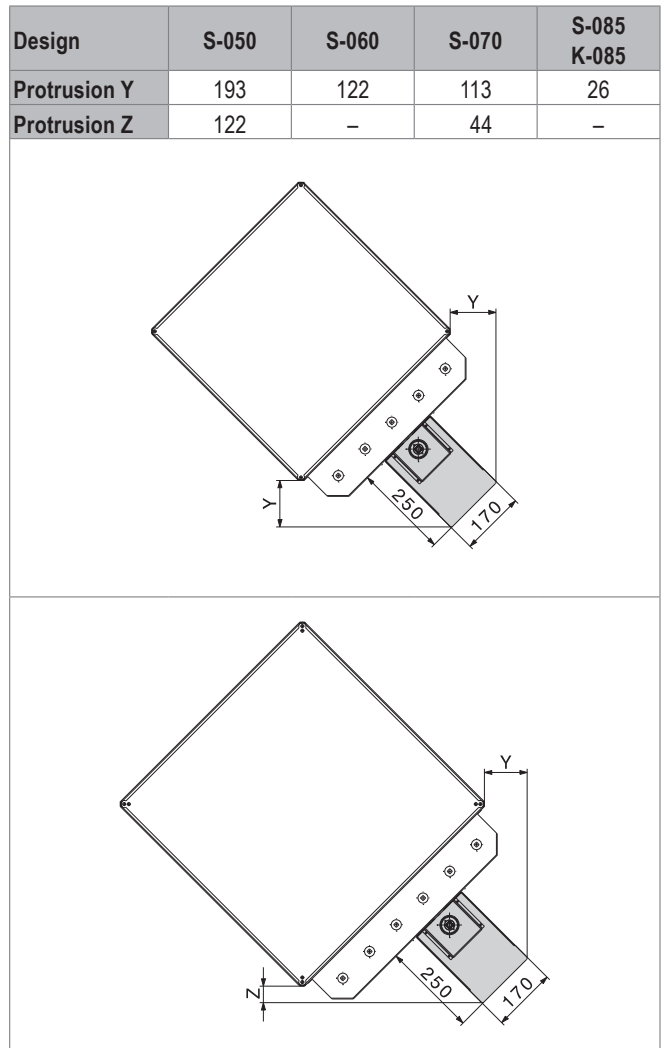

Fig. F9: Dimension sheet adapter for Krivan / design S (in mm)

4 Recirculation bypass

The recirculation bypass enables recirculation and mixed air operation via the plate heat exchanger and thus replaces the mixed air section in the air-conditioning unit. It offers the following advantages:

- The air-conditioning unit can be built shorter.
- There is no narrowing of the cross-section of the air inlet opening.
- The gear wheels are protected from the air stream.

The recirculation bypass is always combined with a bypass for performance control. Depending on the exchanger size, one or more actuators are required to drive the dampers. Drive pins are supplied loose. Install them in the middle of the damper for an optimum force application.

Design	Width (mm)	Quantity	
		Recirculation dampers	Actuators
Side bypass			
G-055 ... G-195	500 ... 2400	1	1
G-225 ... G-255	500 ... 2400	2	2
Middle bypass			
G-055 ... G-195	500 ... 4800	1	1
G-225 ... G-255	500 ... 4800	2	2
Side or middle bypass			
K-085 ... K-170	200 ... 4100	1	1
K-200	200 ... 4100	2	2
S-050 ... S-170	200 ... 4100	1	1
S-200 ... S-240	200 ... 4100	2	2

Table F2: Number of actuators required for the recirculation damper

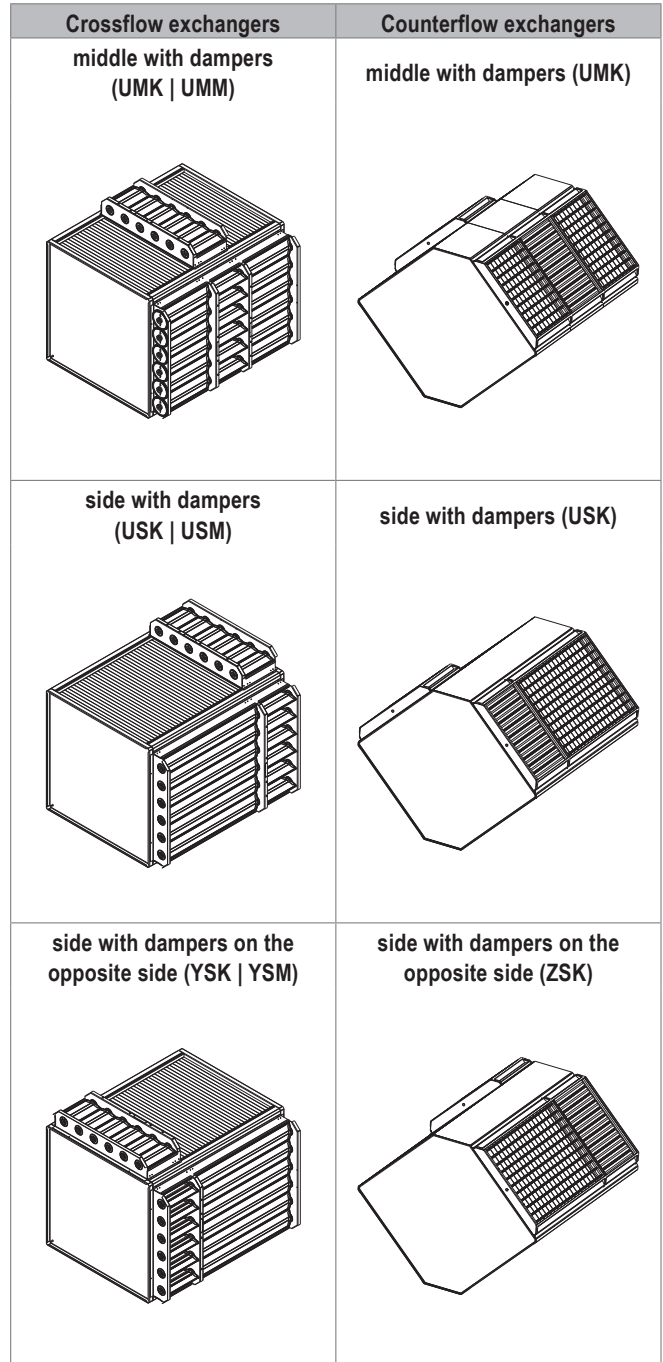

Fig. F10: Recirculation bypass variants

Bypass in the supply air stream	Bypass in the extract air stream	
		<ul style="list-style-type: none"> 1 Extract air 2 Recirculation damper 3 Exhaust air 4 Fresh air 5 Bypass damper 6 Face damper 7 Supply air
<p>Recirculation damper closed Bypass damper 0-100 % ¹⁾ Face damper 0-100 % ¹⁾</p> <p>¹⁾ Control of the energy recovery</p>	<p>Recirculation damper closed Bypass damper 0-100 % ¹⁾ Face damper 0-100 % ¹⁾</p> <p>¹⁾ Control of the energy recovery</p>	<p>Fresh air operation</p>
<p>Recirculation damper open Bypass damper closed Face damper closed</p>	<p>Recirculation damper open Bypass damper open Face damper closed</p>	<p>Recirculation operation</p>
<p>Recirculation damper 0-100 % ¹⁾ Bypass damper 0-100 % ²⁾ Face damper 0-100 % ²⁾</p> <p>¹⁾ Control of the fresh air percentage ²⁾ Control of the energy recovery</p>	<p>not possible</p>	<p>Mixed air operation</p>

Table F3: Arrangement in the ventilation unit

5 Leakage test

Hoval plate heat exchangers are highly leak-tight. The internal air leakage is max. 0.1% of the nominal air volume (at 250 Pa differential pressure). By optional additional sealing of the exchanger package, Hoval can ensure that the exchanger is watertight on delivery:

- 4P – Leakage test on 4 sides

6 Horizontal installation

Note the following for the horizontal installation of plate heat exchangers:

- Arrange the bypass in the middle or at the top.

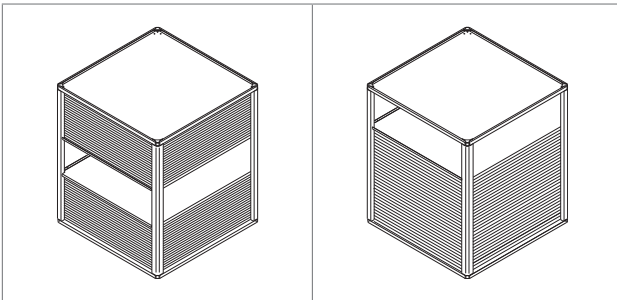

Fig. F11: Bypass in the middle or at the top

- There is a higher icing-up hazard because condensate can remain on the plates. Examine whether an angled installation orientation is possible.
- The condensate drains out without any control. Install a condensate drip tray under the entire exchanger.
- A leakage test is recommended.
- Always order an adapter for actuator.
- The exchanger width in the type code corresponds to the height of horizontally installed exchangers.

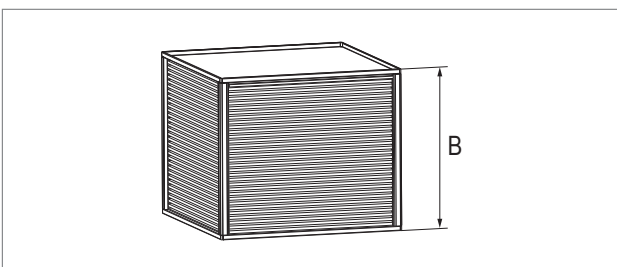

Fig. F12: The width B corresponds to the exchanger height.

Design G (Gotthard)

- For Gotthard exchangers with middle bypass, the “horizontal installation” option is only available up to a width of 2000 mm.

Design S

- To increase stability, supports are fitted in the exchanger package.
- Depending on the size and width of the exchanger, additional reinforcement struts are mounted.

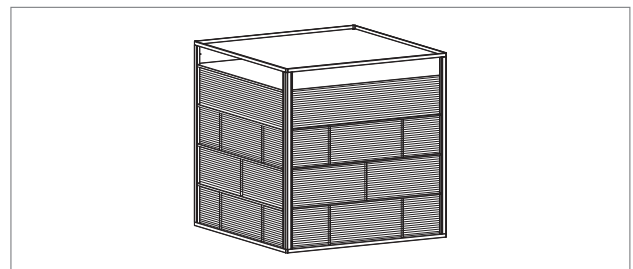

Fig. F13: Exchanger design S with supports and reinforcement struts

7 Stronger packaging

Hoval plate heat exchangers are delivered on wooden pallets and are protected against contamination and moisture by foil. Stronger packaging is required for sea freight or airfreight, consisting of:

- Additional wooden crate on top
- Covering of the exchanger package with wood fibre boards on all 4 sides
- Machine wrapping foil

8 Block supplied loose

Hoval plate heat exchangers composed of several individual exchanger blocks can be supplied loose if required. This facilitates installation into the ventilation unit if space is restricted.

The individual exchanger blocks and possibly the dampers are then assembled on site. Sealing compound, rivets and screws are provided, as are the necessary auxiliary materials. Follow the installation instructions.

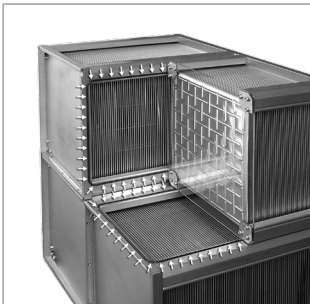

Fig. F14: A circumferential sealing bead in the frame of each exchanger block ensures tight connection of compound exchangers.

9 Optimum order quantity

Gotthard exchangers are particularly inexpensive in certain order quantities, as these quantities are optimal for cost-saving packaging. Transportation is carried out horizontally with a maximum width/height of 1200 mm for each individual exchanger.

Design	Optimum order quantity
G-055, G-065	18 exchangers
G-075, G-085	12 exchangers

Table F4: Optimum order quantities

1 Design programme50
2 Leakage50
3 Pressure difference51
4 Condensation51
5 Frost limit52
6 Pressure drop52
7 Corrosion danger52
8 Cleaning capability53
9 Sound attenuation53
10 Counterflow /parallel flow54
11 ATEX54
12 Twin exchangers54
13 Transport and installation55



System design

1 Design programme

For quick and accurate design of Hoval energy recovery systems, you should use the Hoval CASER design program (Computer Aided Selection of Energy Recovery).



Hoval
CASER

1.1 Availability

You can download the Hoval CASER design program free of charge from our website. It is available in English, German, Italian, Turkish, Swedish, Slovak, French and Chinese. Alternatively, it is also available as a Windows DLL package and can therefore be integrated into other spreadsheet programs (available on request).

1.2 Performance features

The design program offers the following performance features:

- Secure planning thanks to reliable data (Eurovent and TÜV-certified)
- Calculation of a specific Hoval plate heat exchanger or rotary heat exchanger
- Calculation of all appropriate Hoval plate heat exchangers or rotary heat exchangers for a specific project
- Efficiency class in accordance with EN 13053
- Calculation mode “73 air” according to the Ecodesign Directive ErP 1253/2014 (only for plate heat exchangers, for explanation see chapter 1.3)
- Frost limit (only for plate heat exchangers)
- Dynamic calculation of the pressure drop increase due to pressure difference (only for plate heat exchangers)
- Dynamic calculation of the leakage figures EATR (Exhaust Air Transfer Ratio) and OACF (Outdoor Air Correction Factor) (only for rotary heat exchangers)
- Linear calculation of the maximum permissible pressure drop for 1-piece wheels
- Simplified ordering process due to optimised type code
- Price calculation

1.3 Calculation mode

The “73 air” calculation mode filters and sorts the result list of the calculated plate heat exchangers according to the best efficiency/pressure drop ratio. In line with the Ecodesign Directive ErP 1253/2014, 2 values are mathematically combined:

- Thermal efficiency $\eta_{t,nrvu}$
- Internal specific fan power SFP_{int}

The dynamic calculation algorithm considers the pressure drops of the plate heat exchanger and the filters as well as the system efficiencies of the fans and determines a pressure reserve Δp_{HRS} . This value is displayed in the result list. Even during the design of the plate heat exchanger, it shows which theoretical residual pressure drop is still available to fulfil the Ecodesign Directive.

The pressure reserve Δp_{HRS} applies to the reference configuration of a bidirectional ventilation unit (i.e. at least 1 fan per air direction, 1 heat recovery system, 1 supply air filter and 1 extract air filter) and can be used for an economical design of the ventilation unit. Possible measures are:

- Design of a smaller ventilation unit
- Use of less expensive filters with a slightly higher pressure drop
- Use of less expensive fans with a slightly higher power consumption

2 Leakage

Components of air handling units are not normally 100% leakproof. This is mainly because it is not necessary for correct functioning and it would be very expensive. In practical use, however, leakage must remain within technically acceptable limits.

A distinction is made between 2 types of leakage:

- External leakage:
Leakage to the outside is above all a question of assembly quality and normally does not represent any problem.
- Internal leakage:
The leakage between supply air and extract air depends primarily on the product and design. Hoval plate heat exchangers are very leak-tight; the internal leakage is a maximum of 0.1% of the nominal air volume (at 250 Pa pressure difference).

3 Pressure difference

3.1 External pressure difference

The external pressure difference, i.e. the pressure difference between the plate heat exchanger and the environment, is decisive for the external leakage. With correct and careful installation, however, it is insignificant.

More important is the influence of the external pressure difference on the mechanical strength of the exchanger. Particularly the side walls are heavily stressed at big pressure differences.

3.2 Internal pressure difference

The internal pressure difference, i.e. the pressure difference between supply air flow and extract air flow, is an important criterion for the quality of air conditioning systems and deserves special attention during planning.

Internal leakage

The internal pressure difference is decisive for the internal leakage and thus has an effect on the supply air quality. For this reason, note the following when planning:

- Arrange the fans in the ventilation unit so that the pressure difference in the plate heat exchanger is as low as possible.
- Arrange the fans in the ventilation unit so that the pressure drop is directed from the supply air to the extract air. This prevents the supply air quality from being impaired by the extract air in the event of a leakage.



Notice

The differential pressure depends on the arrangement of fans. Overpressure on one side and underpressure on the other side add up.

Pressure drop increase

The internal pressure difference in the plate heat exchanger can cause deformation of the plates, resulting in higher pressure drop and thus higher operating costs. The expected pressure drop increase also depends on the exchanger design and the plate spacing. An exact statement about the pressure drop increase is only possible after a measurement. In the Hoval CASER design programme, the pressure drop increase for the specified internal pressure difference is calculated dynamically on the basis of the measurements.

Determining the pressure difference in the AHU

$$\Delta p_{\text{diff}} = \frac{\Delta p_{21} + \Delta p_{22}}{2} - \frac{\Delta p_{11} + \Delta p_{12}}{2}$$

4 Condensation

Hoval plate heat exchangers can use part of the latent heat of moist extract air. At low outside temperatures, the extract air is cooled down to such a degree that the saturation temperature is reached and condensation is formed. Thus the latent heat of evaporation is released and this reduces further cooling of the extract air. Also the heat transfer is better. The temperature efficiency is raised significantly overall. This can be seen clearly in the hx diagram. The cold air stream is heated more than the warm air is cooled. Nonetheless the enthalpy difference is the same, assuming equal water content.

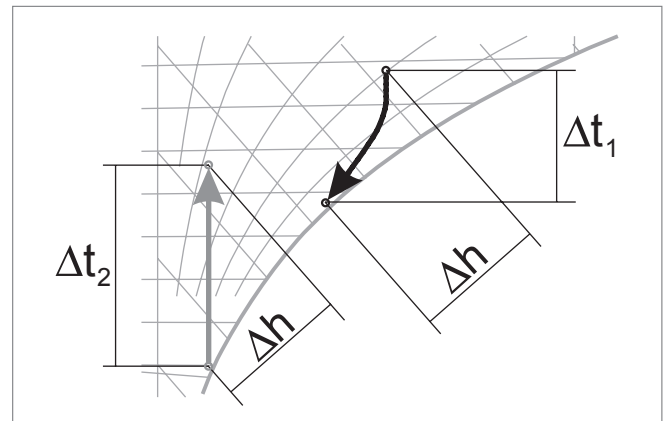

Fig. G1: Changes of condition in the hx diagram

However, condensation in the extract air also narrows the free flow cross-section. The pressure drop is increased. Therefore it is important that the condensation can drain away. This depends mainly on the fitting position of the heat exchanger and on the form of the plates.



Notice

Plate heat exchangers are not 100% water-tight. If condensation occurs the internal and external leakage of the exchanger is of particular importance.

The Hoval CASER design program calculates the expected amount of condensate. Note the following when planning:

- Provide suitable condensate trays and condensate connections and ensure that the condensate can drain freely.
- Observe all relevant regulations (e.g. VDI 6022-1, VDI 3803-1).
- Order plate heat exchangers with the "leak test" option.

5 Frost limit

If the warm extract air stream is very strongly cooled, condensate can be formed and it may even freeze. The fresh air temperature at which freezing starts is called the “frost limit”.

The following circumstances lead to the heat exchanger icing up, starting at the cold corner:

- Very low temperature of the cold air
- High efficiency of the exchanger
- More cold air than warm air (the larger the mass flow ratio m_2/m_1 , the greater the risk of freezing.)
- Relatively little condensation
- Poor condensation drainage due to the installation situation

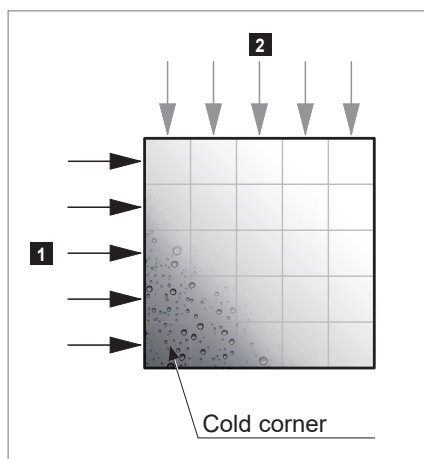

1 Cold air

2 Warm air

Fig. G2: Under extreme conditions the exchanger can ice up, starting at the “cold corner”.

Icing causes the pressure drop to increase accordingly or the air flow rate is reduced. In extreme cases the whole exchanger can slowly ice up. Therefore you should calculate the frost limit for each project with the CASER design programme from Hoval and take necessary precautions.



Notice

If the extract air humidity is less than 4 g/kg, the dew point is below 0 °C, i.e. there is no condensation. The water vapour immediately changes from a gaseous to a solid state and sublimates (→ it “snows”).

6 Pressure drop

Real pressure drops in an energy recovery system usually differ from the calculated values. They depend on various factors:

- Increased pressure drop due to dampers
- Increased pressure drop due to pressure difference
- Increased pressure drop due to condensate, which reduces the flow cross-section
- Increased pressure drop due to the installation situation (changes of direction, narrowing of cross-sections)

Deviations of the measured values from the calculated values can also be due to inaccuracies in measurement. It is important to correctly consider the altitude above sea level and thus the air density when converting mass flow into volume flow.

7 Corrosion danger

The standard exchanger package of Hoval plate heat exchangers in series V consists of 99% pure aluminium. Its resistance to many substances is similar to that of stainless steel 1.4301, and it is slightly more resistant to weak acids than to weak alkalis.

In applications with an increased risk of corrosion – e.g. in swimming pools, kitchens, near the sea and in industry – the G series (corrosion-protected) is usually sufficient. The Hoval technical department will advise which series is suitable for specific applications.

8 Cleaning capability

Dry cleaning	
■	Remove dust and fibres with a soft brush, a vacuum cleaner or compressed air.
■	Use caution when cleaning with compressed air: <ul style="list-style-type: none"> – Min. 20 cm distance between nozzle and exchanger – Max. air pressure 8 bar – Direct the air jet at a right angle to the inflow surface.
Wet cleaning	
■	Remove oils, solvents and similar with hot water and grease solvents. <ul style="list-style-type: none"> – Spray on grease solvents with a spray bottle. – Recommended cleaning agents are, for example: Frosch, Fairy, Largo
■	Remove cleaning agents with a high-pressure cleaner. <ul style="list-style-type: none"> – Use a 40° flat nozzle – Min. 20 cm distance between nozzle and exchanger – Max. water pressure is 100 bar – Direct the water jet at a right angle to the inflow surface.
Disinfection	
■	Spray on disinfectants with a spray bottle. <ul style="list-style-type: none"> – Recommended disinfectants are, for example: Bacillol® 30 Foam, Dr. Becher Schnelldesinfektion
■	Allow disinfectants to act for approx. 30 minutes.
■	Remove disinfectants with a high-pressure cleaner. <ul style="list-style-type: none"> – Use a 40° flat nozzle – Min. 20 cm distance between nozzle and exchanger – Max. water pressure is 100 bar – Direct the water jet at a right angle to the inflow surface.
Descaling	
■	Decalcifier: <ul style="list-style-type: none"> – NALCO ACITOL CL-931 as 10% solution
■	On-site circulation equipment with pH control is necessary.
■	Maintain the pH value below 2.5 during descaling: <ul style="list-style-type: none"> – Add new ACITOL CL-931 as a 10% solution as required.
■	Repeat descaling until no more limescale residues are visually visible.
■	Remove decalcifier with a high-pressure cleaner. <ul style="list-style-type: none"> – Use a 40° flat nozzle – Min. 20 cm distance between nozzle and exchanger – Max. water pressure is 100 bar – Direct the water jet at a right angle to the inflow surface.

Table G1: Cleaning methods for plate heat exchangers



Notice

The minimum space required for cleaning is at least 500 mm in front of and behind the exchanger.

9 Sound attenuation

Plate heat exchangers have a sound-absorbing effect. An exact statement about sound attenuation is only possible after a measurement. An estimate of the insertion attenuation which is sufficiently accurate for most cases can be made using the values given in the tables (see the “Technical data” chapter in each of the various exchanger descriptions).

You can find the attenuation for a given frequency by multiplying the value of the exchanger in question by the frequency correction factor.

Hz	63	125	250	500	1000	2000	4000	8000
f	0.24	0.48	0.67	0.85	1.00	1.15	1.27	1.36

Table G2: Frequency correction factors

Example

Given: Plate heat exchanger SV-085/-X
Attenuation of the sound power ΔL_W at 1000 Hz = 5.5 dB
Find: Attenuation for a frequency of 500 Hz
Solution: $5.5 \times 0.85 = 4.7$ dB



Attention

The sound attenuation applies only for the exchanger package. If the air flows through the bypass no attenuation is to be expected.

10 Counterflow / parallel flow

When installing counterflow heat exchangers and twin heat exchangers, pay attention to the flow direction of the air. The exchangers only achieve the specified efficiency if warm air and cold air are led past each other in counterflow.

If the 2 air streams flow in parallel, efficiency losses of up to 30% occur due to the ever decreasing temperature differential between the warm air and cold air.

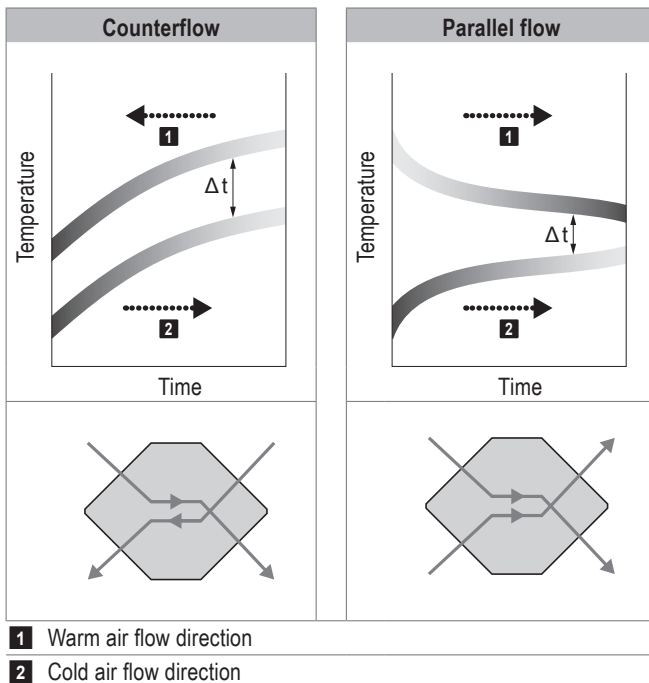

Fig. G3: Counterflow – parallel flow

11 ATEX

The following Hoval plate heat exchangers for use in potentially explosive atmospheres are available on request in accordance with ATEX Directive 2014/34/EU:

- Designs K, S
- Series V
- without dampers

Contact Hoval Application Consulting for further information.

12 Twin exchangers

The term 'twin exchangers' is used when 2 exchangers are fitted in series. The air flows pass through the two plate heat exchangers in counterflow.

Due to the twin arrangement, very good efficiencies can be achieved with relatively small exchangers or with relatively large plate spacings. This saves space and costs. The plate heat exchangers are supplied individually and only installed as twin exchangers in the air-conditioning unit. The total efficiency can easily be calculated with the CASER design program.

i Notice
Dimension an on-site bypass above or below the twin exchanger so that the pressure drop of the bypass corresponds to that of the exchanger package. Otherwise the heat recovery will not be controllable. Contact Hoval Application Consulting for further information.

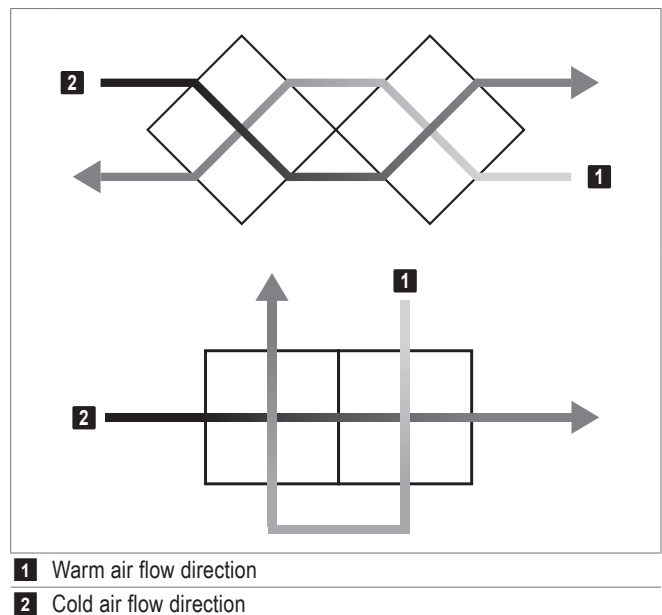

Fig. G4: Classic arrangements of a twin exchanger with air flows passing through

13 Transport and installation

13.1 Transport

- The exchangers may be lifted at the side walls, yet to avoid damage the tensile direction must be vertical (parallel to the side wall). Also lifting facilities (hooks, loops, etc.) may be bolted to the returned edge of the side wall for transportation.
- The reinforcing sections on the side walls may also be used for lifting when present.
- Do not hang the exchanger at the aluminium corner section or at the connection profile. This might cause damage to the corner sealing (leakage).
- Do not lift the exchanger at the reinforcing bar spacers of the bypass.
- Do not lift the exchanger at the dampers.
- In general: Do not lift the exchanger at a single point but always suspend it by a crane beam.

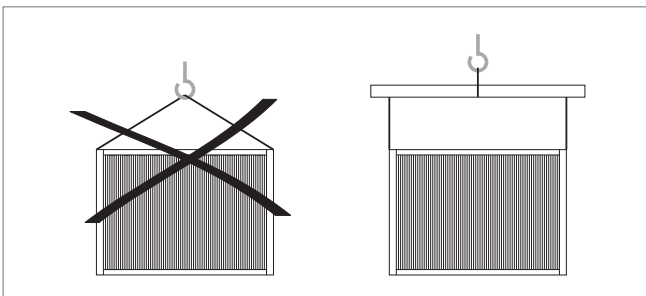

Fig. G5: Do not suspend the exchanger in one point.

13.2 Installation

Hoval plate heat exchangers have no moving parts. Therefore they are easy to install and totally reliable in operation. The following checks must be performed before installation:

- Has the plate heat exchanger been damaged during transport? (visual check of casing and plate package)
- Has the correct type been delivered? (design, series, size, plate spacing, options)
- How is the plate heat exchanger to be positioned? (installation position)

Rotary heat exchangers

Easy to change
brush seal for
high tightness

Storage mass in 3 variants:
for condensation, enthalpy
and sorption wheels



Stepper motor
without gear unit

Space-saving, robust
casing for high
stability and tightness

Hoval energy recovery. You can count on us.

As a specialist for energy recovery systems, Hoval is your reliable partner with decades of experience in the industry. Hoval develops and produces components for heat, cold and moisture recovery for today and tomorrow. The systems are used in ventilation systems and in process technology. You can be sure to save both energy and costs while protecting the environment.

Hoval is one of the leading international companies for energy recovery systems, which are exported worldwide.

Hoval takes its responsibility for the environment seriously. Energy efficiency is at the heart of what we develop.

Responsibility for energy and environment

Hoval Aktiengesellschaft

Austrasse 70

9490 Vaduz

Liechtenstein

Tel. +423 399 24 00

info.er@hoval.com

www.hoval-energyrecovery.com